



TDFM-9200

MULTIBAND P25 AIRBORNE TRANSCEIVER



Installation Instructions

TiL Document No. 13RE472

Rev. D

Issue 5

NOVEMBER 2015

Technisonic Industries Limited

240 Traders Boulevard, Mississauga, Ontario L4Z 1W7
Tel: (905) 890-2113 Fax: (905) 890-5338
www.til.ca

This page is intentionally left blank.

TECHNISONIC INDUSTRIES LIMITED

REVISION HISTORY [13RE472]				
For the most current revision of this document, please check the Technisonic website: www.til.ca				
REV	SECTION - PAGE -	DESCRIPTION	DATE	EDITED BY
A	vi	Corrected DO-160 Information.	July 2013	SM
B	i	Front Panel Image changed.	May 24, 2014	AL
	vi	Minor change to Installation Approval Note.		
	2	Added Special Order Band Codes.		
	2 and 14	Specified "Section 2.17 Configuration Menu" Refers to TDFM-9300 Operating Instructions.		
	7	P/N in Section 2.4 Corrected.		
	9	Added Antenna & Connector Locations as well as Band Display Orientation.		
	15 to 19	Updated Figures 4 – 8.		
	All	Changed Format for Section Headers.		
	All	Corrected Spelling & Grammar throughout document.		
C	vi	Changes made to DO-160G: - Operational Shock and Crash Safety changed to Category B. - Flammability Condition added.	Sep. 11, 2015	AL
	vi	Corrected Installation Approval Note.		
	All	Page Numbers are now sequential.		
D	vi	Flammability Category C refers to Mod 6 only.	Nov. 09, 2015	AL
	34 to 36	Added Environmental Qualification Form.		
D – 1	15 to 19	Updated Figures 4 – 8.	Feb. 16, 2016	AL
D – 2	All	Added band info on new Tri Band RF module.	Apr. 29, 2016	JR
D – 3	iii	Added Website Information to Revision Page.	Oct. 05, 2016	AL
	15 to 19	Updated Figures 4 – 8.		
	20	Minor text fixes.		
	21	Added Section 2.23: Post Installation Adjustment.		
	24	Post Installation EMI Test is now Section 2.24.		
D - 4	26	Updated test frequencies	Feb. 13, 2018	SM
D - 5	19	Added MCP Features	Mar. 4, 2021	SM

This page is intentionally left blank.

NOTES

ESD CAUTION



This unit contains static sensitive devices. Wear a grounded wrist strap and/or conductive gloves when handling printed circuit boards.

FCC COMPLIANCE INFORMATION

This device complies with Part 15 of the FCC Rules. Operation is subject to the following two conditions: (1) this device may not cause harmful interference and (2) this device must accept any interference received, including interference that may cause undesired operation.



WARNING: For compliance with FCC RF Exposure Requirements, the mobile transmitter antenna installation shall comply with the following two conditions:

1. The transmitter antenna gain shall not exceed 3 dBi.
2. The transmitter antenna is required to be located outside of a vehicle and kept at a separation distance of 70 cm or more between the transmitter antenna of this device and persons during operation.

NOTE: This equipment has been tested and found to comply with the limits for a Class A digital device, pursuant to Part 15 of the FCC Rules. These limits are designed to provide reasonable protection against harmful interference when the equipment is operated in a commercial environment. This equipment generates, uses, and can radiate radio frequency energy and, if not installed and used in accordance with the instruction manual, may cause harmful interference to radio communications. Operation of this equipment in a residential area is likely to cause harmful interference, in which case the user will be required to correct the interference at his/her own expense.

WARNING AND DISCLAIMER

Changes or modifications not expressly approved by Technisonic Industries could void the user's authority to operate the equipment.

This manual is designed to provide information about the TDFM-9200. Every effort has been made to make this manual as complete and accurate as possible.

WARRANTY INFORMATION

The Model TDFM-9200 Transceiver is under warranty for one year from date of purchase. Failed units caused by defective parts or workmanship should be returned to:

Technisonic Industries Limited
240 Traders Boulevard
Mississauga, Ontario L4Z 1W7

Tel: (905) 890-2113
Fax: (905) 890-5338

TECHNISONIC INDUSTRIES LIMITED

SUMMARY OF DO-160G ENVIRONMENTAL TESTING

Summary of DO-160G Environmental Testing for Technisonic Model TDFM-9200 Transceiver:

Conditions	Category
Temperature and Altitude	A2, B1, C4, D1
Temperature Variation	B
Humidity	A
Operational shock and Crash Safety	B
Vibration	S, U
Magnetic Effect	Z
Power Input	B
Voltage Spike	B
Audio Frequency Susceptibility	B
Induced Signal Susceptibility	AC
Radio Frequency Susceptibility	T
Radio Frequency Emission	M
Electrostatic Discharge	A
Flammability	C*

* Only applies to units with "MOD 6" marked on the modifications label.

NOTE: TDFM-9200 results are based on TDFM-9300 testing.

For more detailed information, see Appendix A.

INSTALLATION APPROVAL NOTE

Presently, no TSO standard exists for airborne FM transceivers. To make it easier for installation agencies to provide their customers with an approved installation supported by an effective Airworthiness Approval, Technisonic has secured Supplemental Type Certificate (STC) Approvals on its Airborne FM products for a limited number of airframes. The above referenced DO-160G test data is also on file and available from Technisonic to support approval requirements in airframes for which Technisonic does not possess an STC.

Approved aircraft types are listed in the attachments to the formal STC documents. These STCs are the exclusive property of Technisonic and require the written authority of Technisonic for their use. Letters of permission are provided upon request. To assist Factory Authorized Technisonic Dealers in the certification process, we have placed copies of our STCs on our website. These documents may be downloaded and used as support for the technical submission to FAA or Transport Canada. Only authorized factory dealers/installers are permitted to download and make use of these documents on behalf of their customers (end users) in support of regulatory agency approval. Please refer to the Technisonic website www.til.ca for the latest issue of available STCs.

Trademark Notices

TDFM-9200 Transceivers contain two-way radio protocols licensed from Motorola, Inc.

© 1997, 1998 Motorola, Inc.

Motorola KVL 3000+® is a registered trademark of Motorola.

TABLE OF CONTENTS

SECTION	TITLE	PAGE
1	GENERAL DESCRIPTION	
1.1	INTRODUCTION	1
1.2	DESCRIPTION	1
1.3	MODEL VARIATION	1
1.4	TECHNICAL CHARACTERISTICS	4
2	INSTALLATION INSTRUCTIONS	
2.1	GENERAL	7
2.2	EQUIPMENT PACKING LOG	7
2.3	INSTALLATION	7
2.4	INSTALLATION KIT – CONTENTS	7
2.5	ANTENNA INSTALLATION	7
2.6	INSTALLATION – PIN LOCATIONS AND CONNECTIONS	10
2.7	INSTALLATION – WIRING INSTRUCTIONS	14
2.8	MAIN GROUND – J1 PINS 1 AND 14	14
2.9	MAIN POWER + 28 V _{DC} – J1PINS 2 AND 15	14
2.10	MIC 1, 2, 3, 4, AND 5 – J1 PINS 3, 6, 9, J6 PIN 6, AND P1 PIN 15	14
2.11	MIC COMBINED 1 AND 2 – J6 PINS 7 AND 13	14
2.12	AUDIO 1, 2, 3, AND 4 – J1 PINS 4, 7, 10, J6 PIN 5, AND P1 PIN 6	14
2.13	AUDIO COMBINED 1 AND 2 – J6 PINS 2 AND 10	14
2.14	PTT 1, 2, 3, 5, 6, AND 4 – J1 PINS 5, 8, 11, 21, 24, AND J6 PIN 3	15
2.15	PTT COMBINED 1 AND 2 – J6 PINS 4 AND 12.....	15
2.16	TX DATA AND RX DATA – J1 PINS 12 AND 13.....	15
2.17	UP AND DOWN – J1 PINS 16 AND 17.....	15
2.18	CHANNEL/BAND – J1 PIN 18	15
2.19	PANEL BACKLIGHTING – J1 PIN 25	15
2.20	SPEAKER LO AND HI – J6 PINS 8 AND 9	15
2.21	ANTENNA TUNER CONTROL LINES: P1 (PINS 1, 2, 3, 4, 5, 6, 10, AND 12)	15
2.22	ANTENNA SELECTION AND INSTALLATION CONSIDERATIONS	21
2.23	POST INSTALLATION ADJUSTMENT	22
2.24	POST INSTALLATION EMI TEST	25
	APPENDIX A Support Notes	37
	ENVIRONMENTAL QUALIFICATION FORM.....	38
	WARRANTY	41

LIST OF FIGURES

FIGURE	TITLE	PAGE
1	Outline Drawing	8
2	TDFM-9200 Antenna & Connector Locations	9
3	TDFM-9200 Band Display Orientation	9
4	Wiring Connections for Individual Band Control	17
5	Wiring Connections for Combined Band Control	18
6	Wiring Connections for MCP Options	19
7	Wiring Connection Notes for the TDFM-9200 Transceiver	20

LIST OF TABLES

TABLE	TITLE	PAGE
1	J1 25 Pin D Connections	10
2	J6 15 Pin High Density D Connections	11
3	J5 15 Pin High Density D Connections	11
4	J9 26 Pin High Density D Connections (MOD 14 only)	12
5	P1 Wire Connections on a 15 Pin [High Density] FEMALE D Connector	13
6	P2 Wire Connections on a 15 Pin [High Density] FEMALE D Connector	13
7	List of Interface Cables	16

SECTION 1: GENERAL DESCRIPTION

1.1 INTRODUCTION

This publication provides operating information on the TDFM-9200 airborne transceiver. The exact configuration depends on which and how many RF modules are installed.

1.2 DESCRIPTION

The TDFM-9200 transceiver is an airborne multi-band radio capable of operation in conventional analog FM, AM, P25 digital systems, SmartNet/SmartZone trunking systems, and P25 9600 trunking systems. RF modules are available in single, dual or tri bands that support various combinations of VHF LO, VHF AM, VHF FM, UHF-LO, UHF-HI, UHF AM and 700-800 MHz bands. Up to 4 RF bands are supported, with 2 digital multiband modules and 2 analog only RF modules.

Digital modules may include additional features such as P25 9600 trunking Phase 1 and 2 and may be combined with AES and/or DES-OFB encryption with OTAR in any of the available modules.

Bands 1 and 2 on the TDFM-9200 are not normally frequency agile. In order to have the ability to change the frequencies at the front panel, the FPP (front panel programming) option must be ordered for each band. FPP is available on all bands of modules.

The TDFM-9200 has provisions for two of the above digital RF modules as well as two analog only modules. These additional modules are fully frequency programmable from the associated front panel. Analog only modules support CTCSS, DCS, wide, and narrow band operation where applicable.

TDFM-9200 transceivers with MOD 14 (MCP) have the capability to provide PTT, mic and headset for up to 2 (bands 7 and 8) remote handheld transceivers and/or a Latitude Technologies S200-P12 satphone / PTT network com transceiver. Front panel control of the S200-P12 is provided via the display and keypad. Connector J9 provides the MOD 14 interface. See table 6 for a list of recommended interface cables for various hand held transceivers. A digital audio port has been added to interface with the Technisonic TDAP-650 and TDAP-750 digital audio panels.

1.3 MODEL VARIATION

There are several variations of the Model TDFM-9200 Transceiver. Each variation offers different features and performance based on the type of RF modules and options installed.

RF Modules are mounded in trays of two with up to 3 trays supported.

Analog modules occupy a single tray.

The following is a breakdown of the TDFM-9200 model variations:

P/N 121271-D-92-TBB-TB-TB-P9XXXX

(PRODUCT TYPE)-(D)-(9X)-(Tray 1)-(Tray2)-(Tray3)-(Project)

PRODUCT TYPE: 121271 = TDFM 9200 series, 3 trays, 1 or 2 P25 modules and 1 or 2 Analog modules

D= Display type:

- 1) Color TFT
- 2) Standard Green/NV

9X = TDFM-9200 series variant:

92 = TDFM-9200

TECHNISONIC INDUSTRIES LIMITED

Tray Breakdown: (TBB):

T = Module type: A = T30xx RF modules (Single or Dual) or T4000 (Tri Band), T = T3x00 Analog only RF module.

B = Band Code for each module in the tray. See the following tables for supported configurations.

TYPE A Band Codes

	DUAL BAND MODULES (T30xx)			TRI BAND MODULES (T4000)			
SINGLE BAND	1	VHF		5	VHF		
	2	UHF LO		6	UHF LO		
	3	UHF HI		7	UHF HI		
	4	700/800		8	700/800		
DUAL BAND	A	VHF	700/800	M	VHF	700/800	
	B	VHF	UHF LO	N	VHF	UHF LO	
	C	VHF	UHF HI	P	VHF	UHF HI	
	D	UHF LO	UHF HI	R	UHF LO	UHF HI	
	E	UHF LO	700/800	T	UHF LO	700/800	
	F	UHF HI	700/800	V	UHF HI	700/800	
	* G	700/800	VHF	-			
	* H	700/800	UHF LO	-			
	* I	700/800	UHF HI	-			
	* J	UHF LO	VHF	-			
	* K	UHF HI	VHF	-			
	* L	UHF HI	UHF LO	-			
TRI BAND	-			W	VHF	UHF LO	UHF HI
	-			X	UHF LO	UHF HI	700/800
	-			\$ Z	VHF	UHF	700/800

TYPE T Analog Band Codes

ANALOG RF MODULES (T3x00)	
1	VHF LO
4	VHF AM
5	UHF AM

RF BAND COVERAGE

BAND	FREQUENCY RANGE
VHF	136 – 174 MHZ
UHF LO	380 – 470 MHZ
UHF HI	450 – 520 MHZ
700/800	764 – 870 MHZ
UHF	380 – 520 MHZ
VHF LO	30 – 50 MHZ
VHF AM	118 – 136 MHZ
UHF AM	225 – 400 MHZ

TECHNISONIC INDUSTRIES LIMITED

Band numbers indicate Single band equipped modules and letters indicate Dual or Tri band modules.

* Band codes are special order and are not standard configuration.

\$ UHF Band specified covers both the UHF LO and UHF HI as one band. (380 – 520 MHz).

Project Number: P9XXXX represents a 5 digit project number that identifies specific options that are contained in each module and describes the full TDFM-9200 configuration.

All model variations are capable of supporting both 28 Volt and 5 Volt AC or DC back lighting. The units are shipped set to operate on 28 Volt back lighting. Equipment can be set to operate on 5V back lighting by using the software based configuration menu. See Section 2.17 Configuration Menu in the TDFM-9200 Operating Instructions manual available at www.til.ca. Damage will not occur if the incorrect voltage is applied.

1.4 TECHNICAL CHARACTERISTICS

<u>Specification</u>	<u>Characteristic</u>
Model Designation:	TDFM-9200
Physical Dimensions:	Approx. (L) 8.0" x (W) 5.75" x (H) 4.5"
Weight:	~7.0 Lbs (3.2 kg)
Operating Temperature Range:	-30° C to +60° C
Power Requirement:	
Voltage:	28.0 V _{DC} ± 15%
Current:	500 mA minimum / 7.5A maximum
Audio Output Power (including sidetone):	65 mW into 600 Ω
Microphone Inputs:	Carbon or Equivalent
Panel Back Lighting:	
Voltage:	28 or 5 Volts AC or DC (selectable)
Current:	100 mA

RF Modules

<u>Specification</u>	<u>Characteristic</u>
RF Output Power:	1 or 6 Watts (VHF) 1 or 5 Watts (UHF) 1 or 2.5 Watts (764 – 806) 1 or 3 Watts (806 – 870)
Frequency Range	
VHF Band:	136 to 174 MHz
UHF LO Band:	380 to 470 MHz
UHF HI Band:	450 to 520 MHz
UHF Band:	380 to 520 MHz
700 / 800 Bands:	764 to 870 MHz
No. of channels per band:	3000 pre-programmable channels

Transmitter section

	VHF	UHF	800
FM Hum and noise in dB (wideband):	-48	-45	-45
Audio Distortion:	1%	1.0%	1.0%
Frequency Stability in ppm:	± 1.0	± 1.0	± 1.5
Modulation Limiting:	Wide band	± 5 kHz	
	Narrow band	± 2.5 kHz	

Receiver section

	VHF	UHF	800
<i>Sensitivity</i> in uV:			
* Digital 1% BER (12.5 kHz)	0.29	0.32	0.40
* Digital 5% BER (12.5 kHz)	0.21	0.28	0.30
** Analog with 12 dB SINAD	0.25	0.25	0.25
 <i>Selectivity</i> in dB:			
25 kHz Channel	-80	-78	-72
12.5 kHz Channel	-70	-68	-67
Intermodulation * **	-80	-80	-80

* Measured in digital mode per TIA / EIA IS 102.CAAA under nominal conditions.

** Measured in analog mode per TIA / EIA 603 under nominal conditions.

TECHNISONIC INDUSTRIES LIMITED

ANALOG MODULE SPECIFICATIONS

GENERAL

Frequency Ranges:	
VHF FM Lo module	30 - 50 MHz
VHF AM module	118 - 137 MHz
UHF AM module	225 - 400 MHz
Operating Mode:	F3E simplex or semi-duplex (FM modules) A3E simplex (AM modules)
Channel Spacing:	25 or 12.5 kHz (25 kHz only for AM)
FM Frequency Selection: via front panel	200 memories per band programmed with: a) TX Frequency/RX Frequency b) TX/RX CTCSS tone or DPL code c) 9-character alphanumeric title
CTCSS squelch/encoder:	* All CTCSS tones available (FM modules only)
DPL digital squelch/encoder:	* All standard DPL codes (FM modules only)
DTMF encoder:	All standard DTMF tones

* Available only on FM Modules.

VHF LO FM RECEIVER

Sensitivity at 12 dB SINAD	Better than 0.35 μ V
Adjacent Channel Selectivity	-75 dB (25 kHz) -70 dB (12.5 kHz)
Spurious Attenuation	-90 dB
Third Order Intermodulation	-70 dB
Image Attenuation	-80 dB
FM Acceptance	\pm 6 kHz
Hum and Noise	Better than 45 dB
Audio Distortion	Less than 5%
Antenna Conducted Emission	Less than -70 dBm

VHF LO FM TRANSMITTER

RF Power Output	1 watt or 10 watts
Output Impedance	50 ohms
Maximum Deviation	\pm 5 kHz (25 kHz mode)
(In narrowband mode)	\pm 2.5 kHz (12.5 kHz mode)
Spurious Attenuation	-90 dB below carrier level
Frequency Stability	\pm 2.5 ppm
Harmonic Attenuation	-60 dB below carrier level
FM Hum And Noise	-40 dB
Audio Input	50 mV at 2.5 kHz into 200 ohms input circuit for \pm 3.5 kHz deviation, adjust.
Audio Distortion	Less than 5%

TECHNISONIC INDUSTRIES LIMITED

VHF AM RECEIVER

Sensitivity at 12 dB SINAD	Better than 2.0 μ V
Adjacent Channel Selectivity	-70 dB (25 kHz)
Spurious Attenuation	-70 dB
Third Order Intermodulation	-70 dB
Image Attenuation	-60 dB
Hum and Noise	Better than 40 dB
Audio Distortion	Less than 5%
Antenna Conducted Emission	Less than -70 dBm

VHF AM TRANSMITTER

RF Power Output	5 watts (2.5 watts carrier)
Output Impedance	50 ohms
Maximum Modulation (max)	95%
Maximum Modulation (min)	75%
Spurious Attenuation	-60 dB below carrier level
Frequency Stability	\pm 2.5 ppm
Harmonic Attenuation	-60 dB below carrier level
Signal to Noise Ratio	-35 dB
Audio Input	50 mV at 2.5 kHz into 200 ohm input circuit for 30% modulation (adjustable)
Audio Distortion	Less than 5%

UHF AM RECEIVER

Sensitivity at 12 dB SINAD	Better than 4.0 μ V
Adjacent Channel Selectivity	-70 dB (25 kHz)
Spurious Attenuation	-70 dB
Third Order Intermodulation	-70 dB
Image Attenuation	-60 dB
Hum and Noise	Better than 40 dB
Audio Distortion	Less than 5%
Antenna Conducted Emission	Less than -70 dBm

UHF AM TRANSMITTER

RF Power Output	3 to 4 watts carrier
Output Impedance	50 ohms
Maximum Modulation (max)	95%
Maximum Modulation (min)	75%
Spurious Attenuation	-60 dB below carrier level
Frequency Stability	\pm 2.5 ppm
Harmonic Attenuation	-60 dB below carrier level
Signal to Noise Ratio	-35 dB
Audio Input	50 mV at 2.5 kHz into 200 ohm input circuit for 30% modulation (adjustable)
Audio Distortion	Less than 5%

SECTION 2: INSTALLATION INSTRUCTIONS

2.1 GENERAL

This section contains information and instructions for the correct installation of the TDFM-9200 Transceiver.

2.2 EQUIPMENT PACKING LOG

Unpack the equipment and check for any damage that may have occurred during transit. Save the original shipping container for returns due to damage or warranty claims. Check that each item on the packing slip has been shipped in the container.

2.3 INSTALLATION

The TDFM-9200 Transceiver is designed to be Dzus mounted and should be installed in conjunction with an IN-9300 installation kit. See Figure 1 for an outline drawing of the unit with dimensions to facilitate the installation.

2.4 INSTALLATION KIT – CONTENTS

The IN-9300 installation kit (P/N 129292) consists of:

1. One 25 Pin Cannon D mating connector (female) complete with crimp pins and hood.
2. Three 15 Pin HD Cannon D mating connector (female) complete with crimp pins and hood.
3. One 15 Pin HD Cannon D mating connector (male) complete with crimp pins and hood.
4. 4 BNC connectors.

2.5 ANTENNA INSTALLATION

The type and number of antennas depends on the model of transceiver being installed. The following is a list of recommended antennas for the various RF modules:

VHFLO	30 to 50 MHz	Foxtronics Part # FLX-3050B or Sensor Systems Part # S65-8282-34*
VHF AM	118 to 138 MHz	Comant Part # CI-292-1
VHF	136 to 174 MHz	Comant Part # CI-292-3
UHFLO	403 to 470 MHz	Comant Part # CI-275
UHFHI	450 to 520 MHz	Comant Part # CI-285
800	800 to 870 MHz	Comant Part # CI-306
800/700	764 to 870 MHz	Comant Part # CI-285
VHF/UHF/700/800	136 to 870 MHz	RAMI Antennas Part # AV-925

The antenna should be mounted on the bottom of the aircraft whenever possible. Consult with instructions provided with the antenna. Connect the RF cables to the back of the transceiver using the MALE BNC connectors provided in the installation kit. It is possible to use equivalent 50 ohm aviation antennas that cover the appropriate bandwidths.

TECHNISONIC INDUSTRIES LIMITED

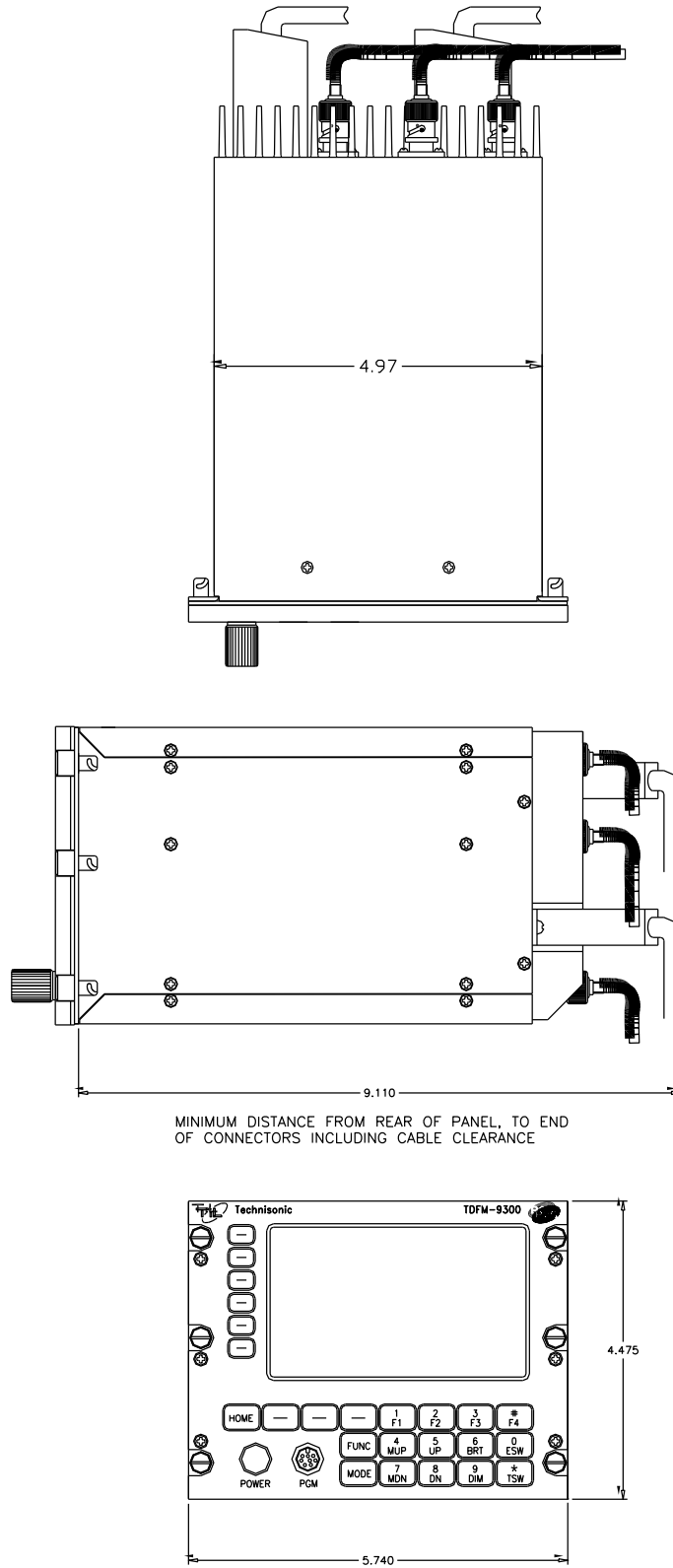

FIGURE 1: Outline Drawing for Model TDFM-9200

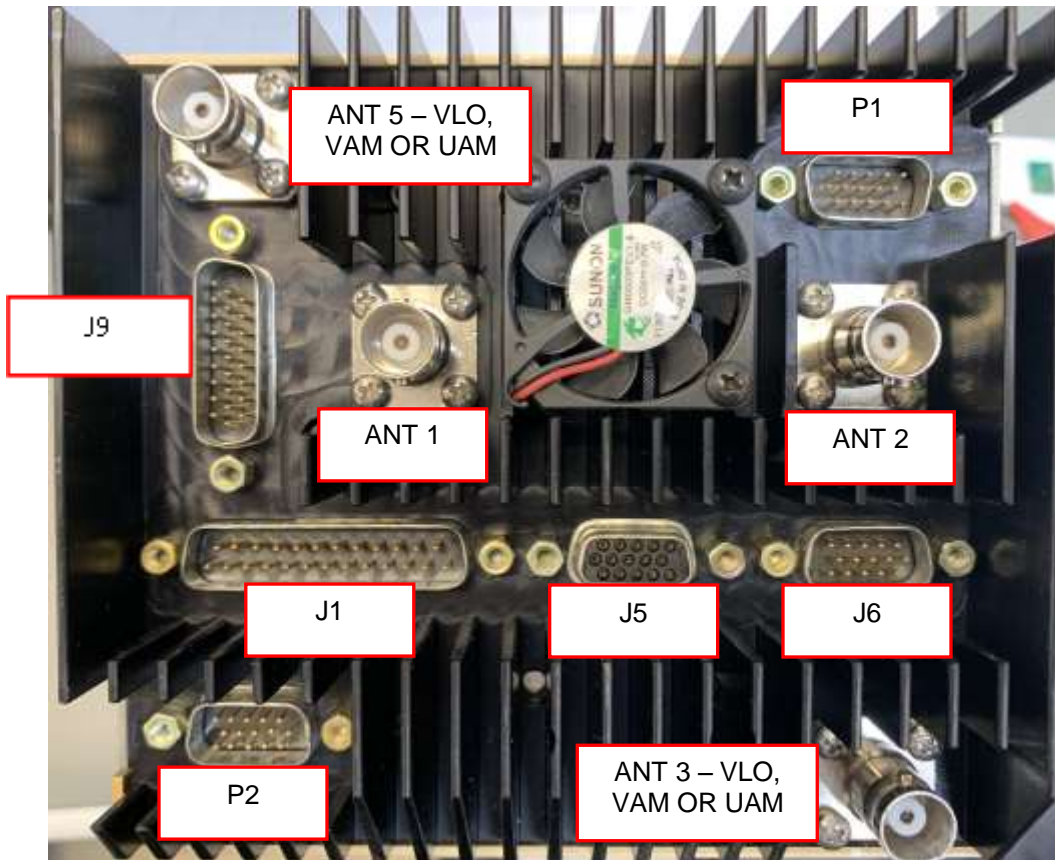

FIGURE 2: TDFM-9200 Antenna & Connector Locations



FIGURE 3: TDFM-9200 Band Display Orientation

TECHNISONIC INDUSTRIES LIMITED

2.6 INSTALLATION – PIN LOCATIONS AND CONNECTIONS

J1 (25 Pin D Connections) - Use FEMALE Connector	
Pin #	Description
1	Ground
2	Main Power +28 V _{DC}
3	Mic 1
4	Audio 1
5	PTT 1
6	Mic 2
7	Audio 2
8	PTT 2
9	Mic 3
10	Audio 3
11	PTT 3
12	TX Data
13	RX Data
14	Ground
15	Main Power +28 V _{DC}
16	Up
17	Down
18	Channel / Band
19	Mic 5
20	Audio 5
21	PTT 5
22	Mic 6
23	Audio 6
24	PTT 6
25	Panel Backlighting

TABLE 1: J1 (25 Pin D) Connections

TECHNISONIC INDUSTRIES LIMITED

J6 (15 Pin High Density D Connections) – Use FEMALE Connector	
Pin #	Description
1	Ground
2	Audio Combined 1
3	PTT4
4	PTT Combined 1
5	Audio 4
6	Mic 4
7	Mic Combined 1
8	Speaker Lo
9	Speaker Hi
10	Audio Combined 2
11	Misc In
12	PTT Combined 2
13	Mic Combined 2
14	Misc In/Out
15	Audio Combined Ground 2

TABLE 2: J6 (15 Pin HDD) Connections

J5 (15 Pin High Density D Connections) – Use MALE Connector	
Pin #	Description
1	Audio 2
2	Audio 5
3	Audio 6
4	Audio 3
5	Audio 4
6	Audio Ground 2
7	Audio Ground 5
8	Audio Ground 6
9	Audio Ground 3
10	Audio Ground 4
11	Audio 1
12	Audio Ground 1
13	Ground
14	Audio Combined Ground 1
15	Audio Combined 1

TABLE 3: J5 (15 Pin HDD) Connections

TECHNISONIC INDUSTRIES LIMITED

J9 (26 Pin High Density D Connections) – Use FEMALE Connector	
Pin #	Description
1	Ground
2	Ground
3	Ground
4	Ground
5	Ground
6	Ground
7	S200-P12 TX Data
8	Not Used
9	Digital Audio Panel Data In
10	Band 7 Mic Out
11	Band 8 Mic Out
12	Band 7 PTT Out
13	Band 8 PTT Out
14	Band 7 Audio Out
15	Band 8 Audio Out
16	Not Used
17	Not Used
18	Not Used
19	Band 7 Mic In
20	Band 8 Mic In
21	Band 7 PTT In
22	Band 8 PTT In
23	Band 7 Audio In
24	Band 8 Audio In
25	S200-P12 RX Data
26	Digital Audio Panel Data Out

TABLE 4: J9 (26 Pin HDD) Connections (MOD 14 Only)

TECHNISONIC INDUSTRIES LIMITED

P1 Connections (15 Pin [High Density] FEMALE D Connector)	
Pin #	Description
1	Band 3 - 4 MHz
2	Band 3 - 8 MHz
3	Band 3 - 10 MHz
4	Band 3 - 20 MHz
5	Band 3 - 40 MHz
6	No connection
7	No connection
8	No connection
9	No connection
10	Band 3 - Tune Indicator
11	No connection
12	Band 3 - Tune Enable
13	Ground
14	No connection
15	No connection

TABLE 5: P1 Wire Connections on a 15 Pin [High-Density] FEMALE D Connector

P2 Connections (15 Pin [High Density] FEMALE D Connector)	
Pin #	Description
1	Band 5 - 4 MHz
2	Band 5 - 8 MHz
3	Band 5 - 10 MHz
4	Band 5 - 20 MHz
5	Band 5 - 40 MHz
6	No connection
7	No connection
8	No connection
9	No connection
10	Band 5 - Tune Indicator
11	No connection
12	Band 5 - Tune Enable
13	Ground
14	No connection
15	No connection

TABLE 6: P2 Wire Connections on a 15 Pin [High-Density] FEMALE D Connector

2.7 INSTALLATION – WIRING INSTRUCTIONS

Figures 4 – 7 show all required connections and recommended wire sizes for the TDFM-9200 transceiver. There are receive audio, mic audio, and Push To Talk (PTT) lines for each band as well as two sets of lines combining all bands. The TDFM-9200 can be wired such that band selection can be made on the audio panel. Up to 7 positions need to be available on the audio panel; otherwise, the TDFM-9200 can be wired into one or two positions of the audio panel where band selection and audio monitoring are done on the TDFM-9200 front panel. An installation can be wired in a combination of both methods since all inputs and outputs are always active.

2.8 MAIN GROUND – J1 PINS 1 AND 14

Both pins should be connected to power ground. These pins are internally connected to the chassis.

2.9 MAIN POWER + 28 V_{DC} – J1 PINS 2 AND 15

Both pins should be connected to +28 volts DC +/- 15%.

2.10 MIC 1, 2, 3, 4, AND 5 – J1 PINS 3, 6, 9, J6 PIN 6, J9 PINS 19 AND 20

The microphone input signals shall be connected using shielded wire with the shield connected to ground (pin 1 or 14). It is recommended for best results to leave the other end of the shield floating to prevent ground currents unless you are connecting to an audio panel with floating hi and lo inputs (like the Technisonic A710, A711, A711L, or TDAP-711) in which case the shield must be connected to the lo input. These are individual inputs for each band.

2.11 MIC COMBINED 1 AND 2 – J6 PINS 7 AND 13

The combined mic inputs should be wired and shielded as the individual mic inputs above. These mic inputs that can be used for any band. Band selection is made at the TDFM-9200 front panel.

2.12 AUDIO 1, 2, 3, 4 – J1 PINS 4, 7, 10, J6 PIN 5, J9 PINS 14 AND 15

These are individual audio outputs from each band. All outputs are 600 ohms impedance. The output power is 65 mW maximum. Unused outputs do not have to be terminated and should be left unconnected.

2.13 AUDIO COMBINED 1 AND 2 – J6 PINS 2 AND 10

These are combined audio outputs from all bands as selected from the front panel. The specifications are the same as the individual outputs above.

2.14 PTT 1, 2, 3, 5, 6, AND 4 – J1 PINS 5, 8, 11, 21, 24, J6 PIN 3, J9 PINS 21 AND 22

There are individual PTT lines for each band. These lines should be floating when in receive and grounded for transmit. The input has a pull up resistor to 5 volts. Connecting an audio panel that wishes to see more may result in no receive audio. Connect a 1N4006 diode in series with the cathode towards the audio panel in this case.

2.15 PTT COMBINED 1 AND 2 – J6 PINS 4 AND 12

These are combined PTT inputs to all bands as selected from the front panel. The specifications are the same as the individual inputs above.

2.16 TX DATA AND RX DATA – J1 PINS 12 AND 13

These pins provide RS-232 serial communications for use with the RC-9000 remote control head if installed. Consult the RC-9000 installation manual for details.

2.17 UP AND DOWN – J1 PINS 16 AND 17

These pins can be used to scroll up and down through the bands or channels for the band currently selected depending on the band input below. The inputs normally floating are grounded to activate. Two push buttons or a center off, SPDT, spring-loaded toggle switch are typically used on these inputs.

2.18 CHANNEL/BAND – J1 PIN 18

The Channel / Band input determines the function of the up down inputs above. If left unconnected, the inputs are for channel selection. If grounded, the input is for band selection.

2.19 PANEL BACKLIGHTING – J1 PIN 25

Connect to aircraft panel dimming bus. The transceiver is capable of supporting 28 V_{AC/DC} or 5 V_{AC/DC} backlighting circuits. Select 28 volts or 5 volts via the configuration menu (see Section 2.17 in the TDFM-9200 Operating Instructions manual). No damage will occur if the wrong setting is made.

2.20 SPEAKER LO AND HI – J6 PINS 8 AND 9

Not normally connected in the aircraft. This output is 4 / 8 ohms at 1.1 watts max and has the audio associated with Audio Combined 1. This output does not have to be terminated when not used and should be left unconnected.

2.21 ANTENNA TUNER CONTROL LINES: P1 (PINS 1, 2, 3, 4, 5, 10, AND 12)

These connections are to control an antenna tuner system such as the Foxtronics FLX-3050B. Connect according to the manufacturer's instructions. In the case of the FLX-3050B, the tune indicator (which is normally connected to a light) can be connected to pin 10 so that the tuning indication will show on the TDFM-9200 display. If a passive antenna is used, these lines shall remain unconnected.

TECHNISONIC INDUSTRIES LIMITED

Hand Held Transceiver Model	Cable Part Number
Motorola Moto-Turbo XPR-6300/6350/6500/6550, SRX-2200, APX-6000/7000/8000	179.6550
Motorola XTS-1500/2500/3000/5000, EFJ-5000, VP Series	179.0630
Harris / Ma/com Jaguar P5300/P5400/P7300, XG75	179.7370
Harris / Ma/com Unity XG-100, XL-200P	179.0641
Kenwood TK190/280/290/380/390/480/481/2140/3140/2180/3180/5210/5400	179.0136
Kenwood NX200, NX300	179.0136
Kenwood TK208/220/240D/248/250/260/270/308/320/340D/348/350/353/360/370/ 430/431272G/372G/3130/3131	179.6013
Icom F30/40/50/60/70/80	179.0160
Icom F3/3S/4/4S/4TR/10, IC-H2/H6/J12/M5/U12/U16	179.0737
Icom A6, F11/11S/14/21/21S/33GS/33GT/43GS/43GT/43TR	179.0748
Yeasu Vertex VX-500/510/520	179.0138
Yeasu Vertex VX-10/210/210A/131/160/180/300/400/410/420	179.0746
Bendix King Relm KNG P150, P400, P500, P800	179.0745
Sincgars PRC-117, MBITR	179.0600

TABLE 7: List of interface cables.

Note: All the above cables interface the TDFM-9200 via a panel mounted locking DIN connector P/N 244.0070.

TECHNISONIC INDUSTRIES LIMITED

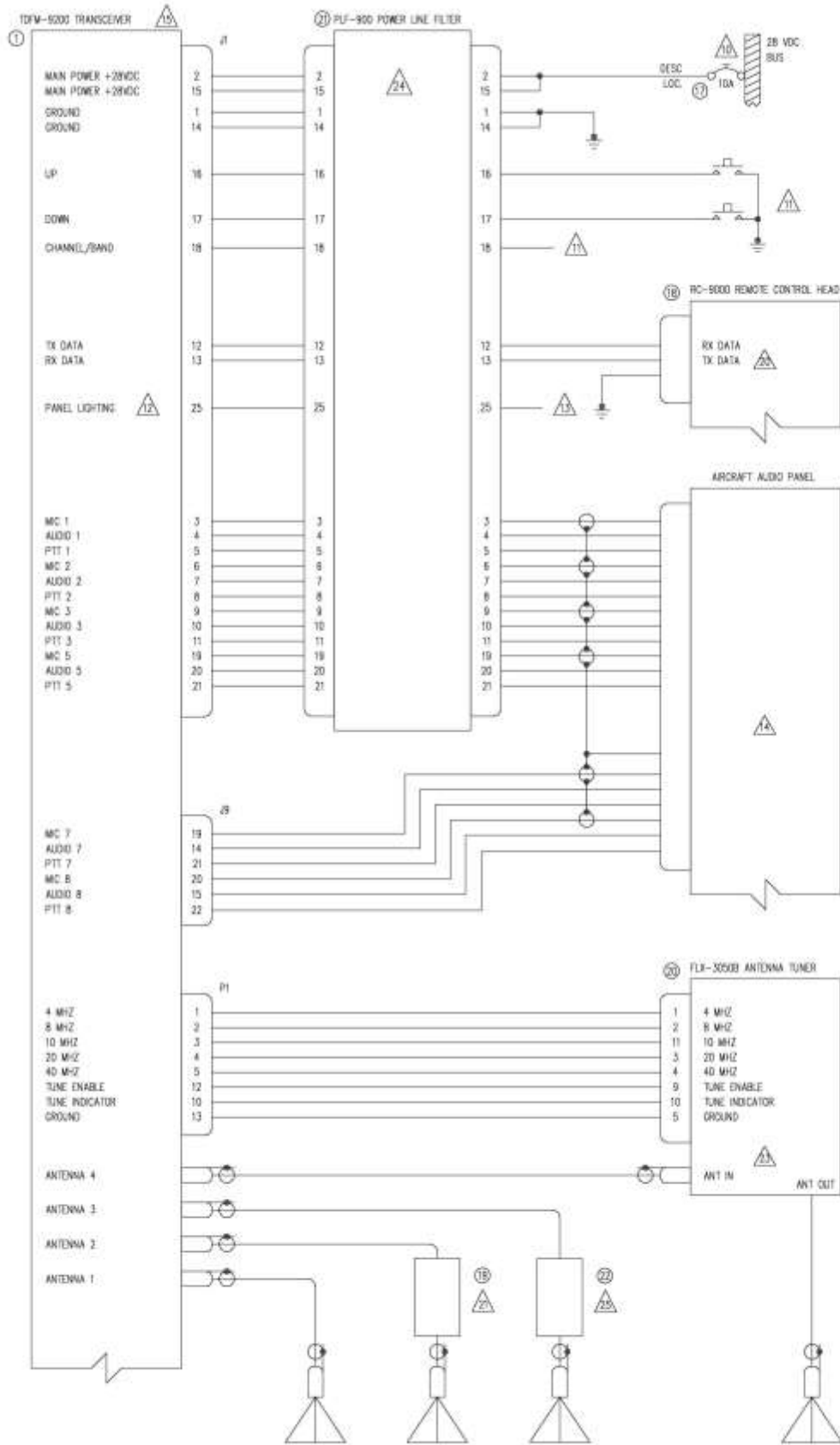

FIGURE 4: Wiring Connections for Individual Band Control.

TECHNISONIC INDUSTRIES LIMITED

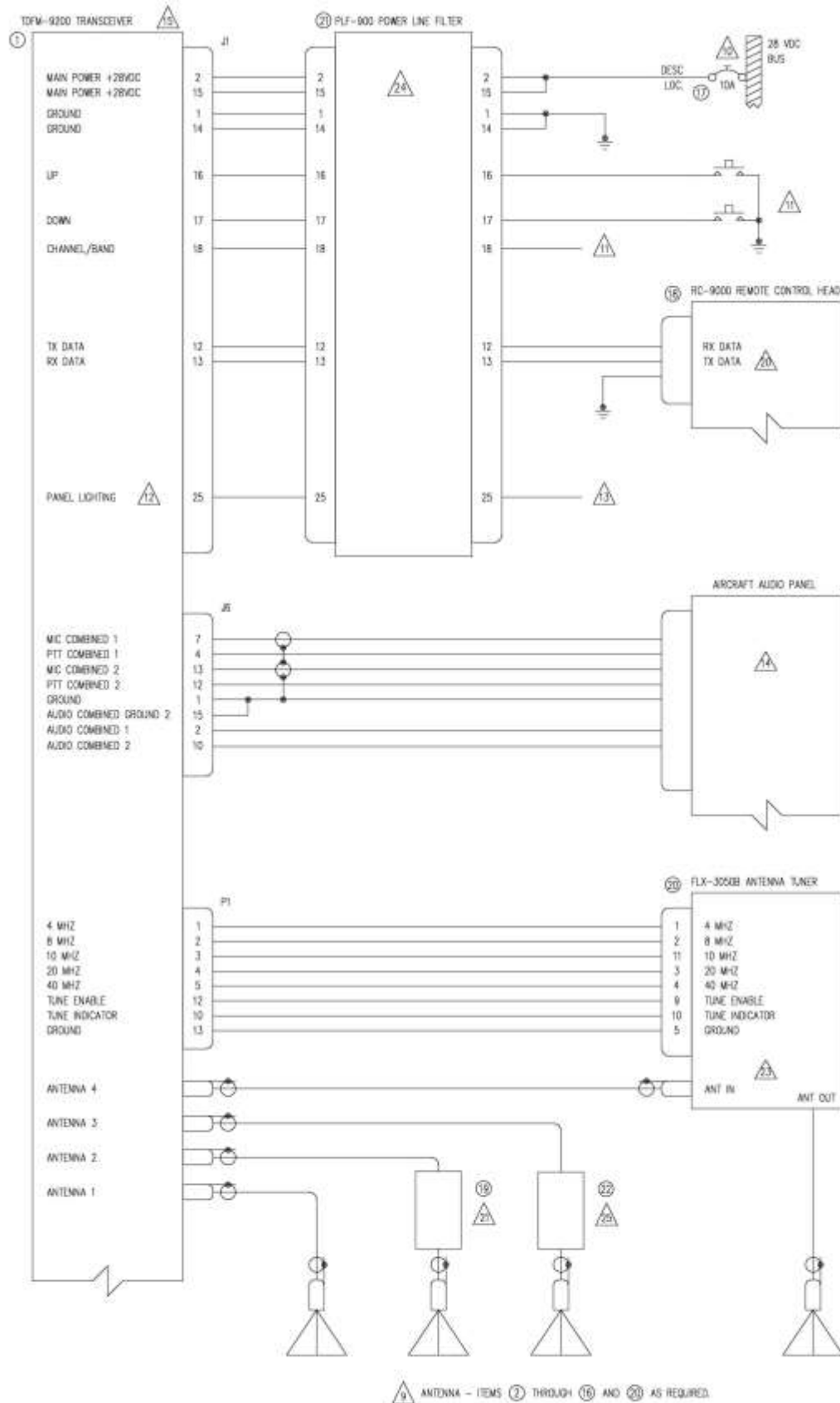

FIGURE 5: Wiring Connections for Combined Band Control.

TECHNISONIC INDUSTRIES LIMITED

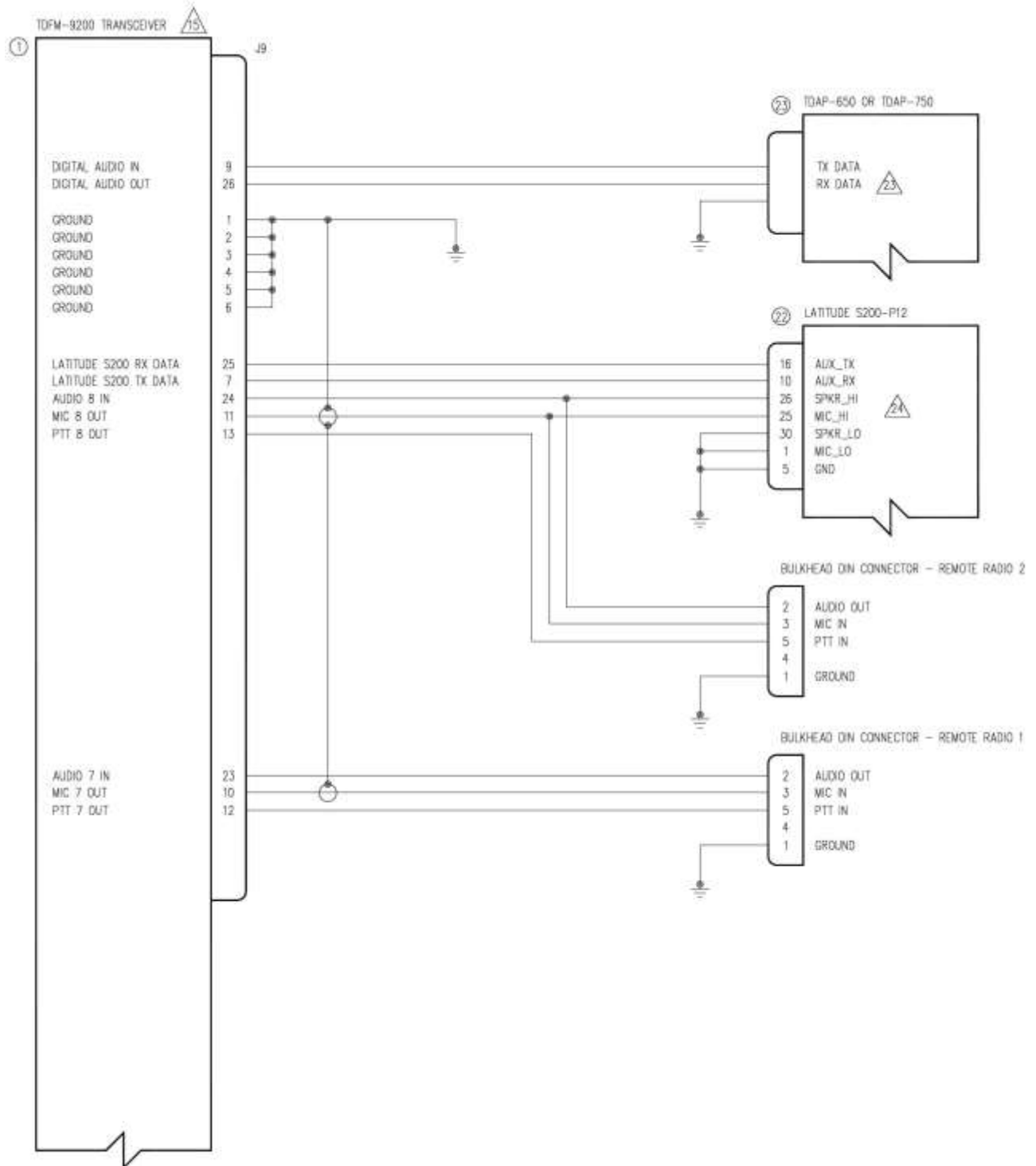

FIGURE 6: Wiring Connections for MCP Options.

TECHNISONIC INDUSTRIES LIMITED

QTY	ITEM	PART NUMBER	DESCRIPTION	MANUFACTURER	MATERIAL
1	1	TDFM-9200	MULTIBAND FM COMMUNICATIONS TRANSCEIVER	TECHNISONIC INDUSTRIES LIMITED	
A/R	2	CI-292-3	VHF ANTENNA, 138 TO 174 MHz	COMANT INDUSTRIES	
A/R	3	CI-292-4	VHF ANTENNA, 136 TO 174 MHz	COMANT INDUSTRIES	
A/R	4	CI-275	UHFLO ANTENNA, 403 TO 470 MHz	COMANT INDUSTRIES	
A/R	5	CI-275	UHFHI ANTENNA, 450 TO 512 MHz	COMANT INDUSTRIES	
A/R	6	CI-285	UHFHI (II) ANTENNA, 450 TO 520 MHz	COMANT INDUSTRIES	
A/R	7	CI-306	800 ANTENNA, 806 TO 870 MHz	COMANT INDUSTRIES	
A/R	8	CI-285	800/700 (II) ANTENNA, 700 TO 870 MHz	COMANT INDUSTRIES	
A/R	9	CI-295-200	VHF/UHF ANTENNA, 136 TO 174 / 380 TO 520 MHz	COMANT INDUSTRIES	
A/R	10	CI-295-250	VHF/700/800 ANTENNA, 136 TO 174 / 764 TO 870 MHz	COMANT INDUSTRIES	
A/R	11	21-50-45	VHF/UHF/700/800 ANTENNA, 136 TO 174 / 380 TO 870 MHz	COOPER ANTENNAS	
A/R	12	AV-925	VHF/UHF/700/800 ANTENNA, 136 TO 174 / 380 TO 520 / 760 TO 870 MHz	RAMI ANTENNAS	
A/R	13	AT-1108/ARC	VHF/UHF ANTENNA, 116 TO 152 / 225 TO 400 MHz	RAMI ANTENNAS	
A/R	14	S65-8282-34	VHF LO/VHF/UHF ANTENNA, 30 TO 88 / 108 TO 174 / 225 TO 400 MHz	SENSOR SYSTEMS INC.	
A/R	15	S65-1227	UHF ANTENNA, 225 TO 400 MHz	SENSOR SYSTEMS INC.	
A/R	16	AT-256A/ARC	UHF ANTENNA, 225 TO 400 MHz	RAMI ANTENNAS	
1	17	7274-11-10	CIRCUIT BREAKER, 10 AMPS	KLIXON	
A/R	18	RC-9000	REMOTE CONTROL HEAD	TECHNISONIC INDUSTRIES LIMITED	
A/R	19	SRA-6000	SWITCHED RECEIVE ATTENUATOR	TECHNISONIC INDUSTRIES LIMITED	
A/R	20	FLX-3050B	VHF LO ANTENNA / ANTENNA TUNER	FOXTRONICS INC.	
A/R	21	PLF-900	POWER LINE FILTER	TECHNISONIC INDUSTRIES LIMITED	
A/R	22	133956-1	VHF HIGH PASS FILTER	TECHNISONIC INDUSTRIES LIMITED	

NOTES:

- 1) ALL WIRE IAW MIL-W-22759 UNLESS OTHERWISE SPECIFIED.
- 2) ALL CABLE IAW MIL-C-27500 UNLESS OTHERWISE SPECIFIED.
- 3) COAXIAL CABLE IAW MIL-C-17 UNLESS OTHERWISE SPECIFIED. DO NOT USE COAX WITH PVC INSULATION.
- 4) FABRICATION & INSTALLATION OF WIRING HARNESS IAW AC 43.13-1B CHAPTER 11.
- 5) GROUNDING AND BONDING IAW AC 43.13-1B CHAPTER 11, SECTION 15.
- 6) ALL SINGLE WIRE TO BE #22 AWG MINIMUM AND ALL SHIELDED WIRE TO BE #24 AWG MINIMUM, UNLESS OTHERWISE SPECIFIED.
- 7) POWER AND GROUND WIRES TO BE #20 AWG.
- 8) ANTENNA COAX TO BE RG-142/U OR EQUIVALENT.
- 9) INSTALLATION OF ANTENNA IAW AC 43.13-1B CHAPTER 4, SECTION 4, CHAPTERS 6 & 7, AND AC 43.13-2A CHAPTER 3. IF POSSIBLE, THE ANTENNA SHOULD BE LOCATED A MINIMUM OF 12 FT FROM AIRCRAFT NAVIGATION RECEIVER ANTENNAS AND A MINIMUM OF 4 FEET FROM AIRCRAFT COMMUNICATIONS AND ELT ANTENNAS. BE CAREFUL NOT TO CHOOSE SEPARATIONS THAT CLOSELY APPROXIMATE 1/4 OR 1/2 OR WHOLE NUMBER MULTIPLES OF THE NAVIGATION OR COMMUNICATIONS WAVELENGTH.
- 10) AN EQUIVALENT CIRCUIT BREAKER OR FUSE MAY BE USED.
- 11) THE CHANNEL/BAND UP/DOWN PUSH BUTTONS ARE OPTIONAL. GROUND CHANNEL/BAND INPUT FOR BAND CONTROL, LEAVE UNCONNECTED FOR CHANNEL CONTROL.
- 12) THIS INPUT IS FOR BOTH 28 VDC AND 5 VAC PANEL LIGHTING. SELECT THE APPROPRIATE VOLTAGE IN THE CONFIGURATION MENU.
- 13) CONNECT TO THE APPROPRIATE AIRCRAFT DIMMING BUSS.
- 14) CONNECT TO THE AIRCRAFT AUDIO SYSTEM OR STAND-ALONE HEADSET JACKS.
- 15) INSTALLATION OF TRANSCEIVER IAW AC 43.13-1B CHAPTER 4, SECTION 4 AND AC 43.13-2A, CHAPTER 2. PR3 1/2 DZUS RAIL OR EQUIVALENT MAY BE USED.
- 16) TEST THE SYSTEM IN ACCORDANCE WITH THE POST-INSTALLATION TEST PROCEDURE IN THE INSTALLATION INSTRUCTIONS MANUAL.
- 17) REFER TO THE AIRCRAFT STRUCTURAL REPAIR MANUAL AND THE MAINTENANCE MANUAL FOR INSTRUCTIONS AND INFORMATION PERTINENT TO THIS INSTALLATION.
- 18) THE USE OF RED DISPLAYS SHOULD BE MINIMIZED OR AVOIDED SO AS NOT TO DETRACT FROM THE ATTENTION GETTING CHARACTERISTICS NEEDED IN WARNING AND CAUTION ANNUNCIATORS. RED SHOULD BE USED TO ANNUNCIATE EMERGENCY CONDITIONS REQUIRING IMMEDIATE RESPONSE BY THE FLIGHT CREW. UNITS WITH RED DISPLAYS SHOULD NOT BE LOCATED IN CLOSE PROXIMITY TO WARNING AND CAUTION ANNUNCIATORS. THE INSTALLATION OF UNITS WITH RED DISPLAYS MUST BE EVALUATED ON A CASE BY CASE BASIS TO ENSURE THAT THE EFFECTIVENESS OF THE WARNING AND CAUTION ANNUNCIATORS IS NOT ADVERSELY AFFECTED.
- 19) NOT NORMALLY USED IN AIRCRAFT.
- 20) CONNECTION TO AN OPTIONAL RC-9000 SLAVE CONTROL HEAD.
- 21) CONNECTION TO AN OPTIONAL SRA-6000 SWITCHED RECEIVE ATTENUATOR.
- 22) NOT USED.
- 23) CONNECTION TO OPTIONAL ANTENNA TUNER SYSTEM. SEE MANUAL FOR INSTALLATION INSTRUCTIONS AND POWER CONNECTIONS.
- 24) OPTIONAL POWER LINE FILTER.
- 24) OPTIONAL VHF HIGH PASS FILTER.

FIGURE 8: Wiring Connection Notes for the TDFM-9200 Transceiver

2.22 ANTENNA SELECTION AND INSTALLATION CONSIDERATIONS

Antenna installations will vary according to the number / type of bands installed in the TDFM-9200, types of antennas selected, and space available on the aircraft. The materials list above contains many but not all antennas available. If dual or tri band RF modules are installed in the TDFM-9200, it is suggested to use a single connector, multiband antenna for each of the RF modules installed. When single band modules are installed, a single band antenna should be used.

If the TDFM-9200 has more than one single band module installed that are on different frequency bands, a single multiband antenna with separate connectors or a multiband antenna with a coupler can be used if the frequencies in use are not multiples of each other. For example, transmitting near 150 MHz on VHF may interfere with frequencies near 450 MHz on the UHF band. Antennas should be spaced as far as possible from each other with the Comm antennas on the opposite side (top or bottom) from the FM antennas.

The following example uses a single RAMI AV-925 antenna and triplexer AV-926 with up to three single band modules operating in the following Frequency ranges:

- 136-174 MHz
- 380-520 MHz
- 764-870 MHz

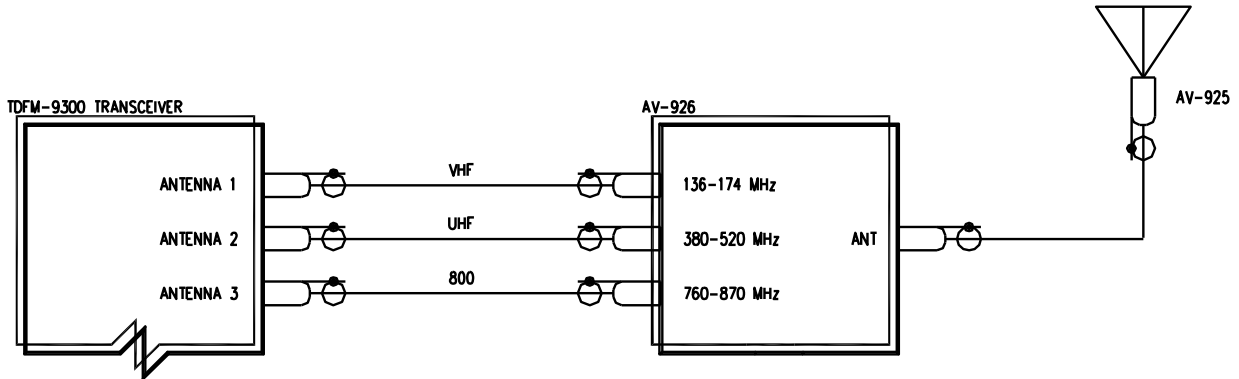

2.23 POST INSTALLATION ADJUSTMENT

In most cases, factory audio settings will work; however, if there is a need to adjust audio levels to match the audio controller system, then they can be adjusted in Maintenance Menu. To reach the Maintenance Menu, press FUNC – NEXT and select Configuration from the 2nd side button. Then press the MODE key.

First Page – TX Mic Gains

Mic 1 Level: 24

The Mic gain levels can be adjusted from 0 to 40 with a typical factory setting of 22 to 24 for bands 1 & 2 (Band 3 & 5 is 20). The higher the number, the more sensitive the mic input is. The factory setting gives approximately 1.5 kHz deviation for – 13 dBm for a 600 ohm system. Highlight the desired band by pressing the corresponding side button. Key the selected band and rotate the knob to adjust the mic gain to a desired level. Unkey the radio. Repeat for the other bands as required.

Press NEXT to reach the next screen.

Second page - RX audio levels.

RX Audio 1 level: 14

This page sets the MAX RX audio level the volume has when set to 40 on the normal operational display screen. The maximum RX audio level on each module installed can be adjusted from 0 to 40 with a typical factory setting for bands 1 & 2 of 10 to 14 for 5 Vrms for 600 ohm load. Bands 3 & 5 is 30 to 35. The higher the number, the higher the max audio is. Highlight the desired band by pressing the corresponding side button. Rotate the knob to adjust the Maximum RX level. Repeat for other bands as required.

Note: The factory level is optimized for highest level with the lowest distortion. Adjusting further than factory settings will result in little gain and higher RX distortion. Normally this level should only be lowered if the audio controller needs a lower level of drive.

Press NEXT to reach the next screen.

TECHNISONIC INDUSTRIES LIMITED

Third Page – Keypad Backlight Calibration

Keypad Calibration – 28 V_{DC}: 1800

Keypad Calibration – 5 V_{AC}: 400

The keypad backlight maximum brightness can be adjusted here. Two menus available are 28V and 5V. The active menu depends on the Backlight Mode selected in the Configuration Menu. The 28V menu can be adjusted if the radio is set for 28V or the 5V menu can be adjusted if the radio is set for 5V.

The 28V menu is adjustable from 500 to 2500 and the 5V is adjustable from 100 to 1000. The calibration value determines the maximum brightness the keypad will be allowed to go to when the max backlight voltage is applied the back light buss input. The *higher* the number, the *lower* the brightness. This feature may be useful for matching the NV backlighting of the TDFM-9200 to the airframe installation setup.

In the Configuration Menu, select the Backlight Mode – 28 V_{DC} or 5 V_{AC} (5th item). Set the dimming bus in the airframe to maximum value. Rotate the knob to adjust the max brightness of the keypad to the desired level.

Mod 7 Menu: Enabled

The Mod 7 menu should be set on if the radio's modification record label has Mod 7 marked. Otherwise, it should be disabled. Highlight the menu and rotate the knob to adjust as required.

NOTE: This is a factory setting and should not be adjusted in the field unless directed to do so.

Press NEXT to reach the next screen.

TECHNISONIC INDUSTRIES LIMITED

Fourth Page - Bands 3 & 5 TX Power and Squelch Settings.

RFM 3 RX Sqlch 215
RFM 5 RX Sqlch 215

This sets the Receive Squelch level for the analog RF modules installed for Bands 3 & 5 slots. The Squelch can be set from 0 to 255. The typical factory setting is 215. Highlight the Menu and rotate the knob to adjust as required. The higher the number, the tighter the squelch.

RFM 3 TX HI PWR 235
RFM 5 TX HI PWR 235

This sets the Transmit HI Power level for the VHF Low Band RF Module for radios so equipped in Band 3 or 5 slots. TX power can be adjusted from 0 to 255 (with a typical factory setting of 235 for 10 W output). Highlight the Menu, key the module, and rotate the knob to adjust as required.

RFM 3 TX LO PWR 064
RFM 5 TX LO PWR 064

This sets the Transmit LO Power level for the VHF Low Band RF Module for radios so equipped in bands 3 or 5 slots. TX power can be adjusted from 0 to 255 (with a typical factory setting of 064 for 1 W output). Highlight the Menu, key the module, and rotate the knob to adjust as required.

NOTE: The Transmit Power Menus are not displayed for modules VHF AM or UHF AM. AM RF modules have fixed transmit power and are not user adjustable.

Press ESC to return to normal operation.

2.24 POST INSTALLATION EMI TEST

PURPOSE

The purpose of this test is to identify any interference that the TDFM-9200 transceiver may cause with existing aircraft systems.

TEST CONDITIONS

The TDFM-9200 transceiver should be installed and function tested. The antenna VSWR should be checked. A forward/reverse power check with an in-line wattmeter should show no more than 10% reflected power. For the following tests, ensure that the output power is set to high.

METHODOLOGY

Most of the EMI tests can be accomplished on the ground. In some cases, flight testing is required or is easier. If the aircraft is approved for IFR operations, then it is mandatory that interference between the TDFM-9200 transceiver and the approach aids be checked in flight.

The GPS should be operational and navigating with at least the minimum compliment of satellites. The VHF comm should be set to the frequencies indicated with the squelch open. VOR/DME receivers should be set to the frequencies indicated and selected for display. If possible, set up a DME ramp test set on the frequencies indicated and adjust the output until the flags are out of view. The transponder and encoder should be monitored with ramp test equipment. Set the output of the transponder test set to 3db above the output necessary to achieve 90% reply. If possible, set the ADF to a nearby navigation station.

Modulate the TDFM-9200 transmitter on the indicated frequencies for at least 20 seconds.

Observe the GPS for any degradation in satellite status or availability or flags. Listen for any noise or detected audio signals on the VHF comm(s). Listen for any noise or detected audio signals on the VOR/LOC receiver audio; look for any moment of flags or needles on the VOR/LOC/GS navigation display(s). Observe the transponder for any loss of reply or spurious reply.

List the power plant, fuel, and other electric instruments in the chart provided and note any anomalies that occur while transmitting. Assess the results.

If the aircraft is equipped with an autopilot or a stability augmentation system, then test fly the aircraft and verify that operation of the TDFM-9200 transceiver does not have adverse effects on these systems. After checking for gross effects at a safe altitude, fly an approach with each of the different navigation systems coupled to the autopilot (ILS, GPS, etc.) and look for any anomalies.

RESULTS

If the installed system passes all of the applicable EMI tests, then no further action is required. If interference is observed, then the interference must be assessed against the appropriate standards of airworthiness for the system in question. For example, it is permissible for a VFR certified GPS to lose navigation capability while the TDFM-9200 unit is transmitting, providing that it recovers properly and promptly, but it is not permissible for an IFR Approach certified GPS to be affected in the same way. A complete discussion of all the standards of airworthiness to be applied in assessing EMI effects is beyond the scope of this document.

TECHNISONIC INDUSTRIES LIMITED

PROCEDURE

- A. Operate the TDFM-9200 transmitter on the following frequency for at least 20 seconds. Observe the GPS for any degradation in satellite status or availability or flags.

FREQUENCIES	GPS #1		GPS #2	
	PASS	FAIL	PASS	FAIL
143.2125 MHz				
143.2250 MHz				
157.5375 MHz				
157.5500 MHz				
512.0000 MHz				
39.3850 MHz				

NOTES:

TECHNISONIC INDUSTRIES LIMITED

- B.** Determine if the image frequency for the VHF Comm falls within the range of the TDFM-9200. If so, select a set of frequencies that will cause the TDFM-9200 to be set as close as possible to the image frequency. Any one of the many possible sets will suffice. Record those values in the spaces provided in the following chart. Modulate the TDFM-9200 transmitter on the following frequencies for at least 20 seconds. Listen for any noise or detected audio signals on the VHF comm.

Example - Bendix/King KY 196A:

The first IF frequency is 11.4 MHz. The L.O. is above the received frequency (high side injection); therefore, the image frequency is 22.8 MHz above the selected frequency. Set the KY 196A to 120.000 MHz and the TDFM-9200 to 142.8000 MHz.

FREQUENCIES		RESULTS	
VHF #1	TDFM-9200	PASS	FAIL
135.975	138.0000		
121.150	157.5000		
131.250	157.5000		
118.000	34.000		
118.000	45.000		
Image:			

FREQUENCIES		RESULTS	
VHF #2	TDFM-9200	PASS	FAIL
135.975	138.0000		
121.150	157.5000		
131.250	157.5000		
118.000	34.000		
118.000	45.000		
Image:			

TECHNISONIC INDUSTRIES LIMITED

NOTES:

TECHNISONIC INDUSTRIES LIMITED

- C.** Determine if the image frequency for the VOR/ILS Nav falls within the range of the TDFM-9200. If so, select two sets of frequencies that will cause the TDFM-9200 to be set as close as possible to the image frequency. Choose one set in the localizer frequency range and one in the VOR frequency range. Record those values in the spaces provided in the following chart. Modulate the TDFM-9200 transmitter on the following frequencies for at least 20 seconds. Listen for any noise or detected audio signals on the receiver audio; look for any moment of flags or needles on the navigation display.

FREQUENCIES		RESULTS	
VOR/ILS #1	TDFM-9200	PASS	FAIL
108.000	162.0000		
108.100	162.1500		
108.000	36.0000		
108.100	36.0325		
Image:			

FREQUENCIES		RESULTS	
VOR/ILS #2	TDFM-9200	PASS	FAIL
108.000	162.0000		
108.100	162.1500		
108.000	36.0000		
108.100	36.0325		
Image:			

NOTES:

TECHNISONIC INDUSTRIES LIMITED

- D.** The following procedure checks for second harmonic interference to the glide slope receiver from the TDFM-9200. All transceivers produce harmonics (multiples of the wanted frequency) and while the TDFM-9200 far exceeds FCC requirements, interference can still be experienced depending upon antenna position and separation. Furthermore, other equipment in the aircraft and the structure of the aircraft can generate harmonics where dissimilar metals make contact or where grounds are isolated, etc. This is also true of aircraft hangars; therefore, testing should be done outside away from any structures where possible.

With a portable glide slope generator, provide enough signal to firmly activate the indicator needle and hide all flags. Increase the signal level by 3 dB. Modulate the TDFM-9200 transmitter on the following frequencies for at least 20 seconds. Observe the Glide Slope displays. Look for any movement of flags or needles on the navigation display. If an interference condition is detected, then the installation will have to be flight tested according to the following procedure. Using the table below, determine the glide slope frequency based on the localizer frequency of the ILS to be used. Divide the glide slope frequency by 2 and program into the TDFM-9200. Fly the aircraft to intercept the localizer and glide slope (both needles centered) at 26 nm from the runway. Transmit on the TDFM-9200 for 10 seconds and watch for any deflections or flags. Repeat the test every 2 nm until the indicators are not affected. If the distance is greater than 18 nm, then a pass shall be recorded. Otherwise the TDFM-9200 shall be placarded "Do not transmit while on ILS approach."

Localizer	Glide slope	Localizer	Glide slope
108.10	334.70	110.10	334.40
108.15	334.55	110.15	334.25
108.30	334.10	110.30	335.00
108.35	333.95	110.35	334.85
108.50	329.90	110.50	329.60
108.55	329.75	110.55	329.45
108.70	330.50	110.70	330.20
108.75	330.35	110.75	330.05
108.90	329.30	110.90	330.80
108.95	329.15	110.95	330.65
109.10	331.40	111.10	331.70
109.15	331.25	111.15	331.55
109.30	332.00	111.30	332.30
109.35	331.85	111.35	332.15
109.50	332.60	111.50	332.90
109.55	332.35	111.55	332.75
109.70	333.20	111.70	333.50
109.75	333.05	111.75	333.35
109.90	333.80	111.90	331.10
109.95	333.65	111.95	330.95

TECHNISONIC INDUSTRIES LIMITED

FREQUENCIES		RESULTS	
G/S #1	TDFM-9200	PASS	FAIL
334.7 (108.1)	167.35		
334.7 (108.1)	33.4700		

FREQUENCIES		RESULTS	
G/S #2	TDFM-9200	PASS	FAIL
334.7 (108.1)	167.35		
334.7 (108.1)	33.4700		

NOTES:

- E. Operate the TDFM-9200 transmitter on the following frequency for at least 20 seconds. Observe the Transponder for any spurious replies or loss of reply to test set.

FREQUENCIES	TRANSPONDER #1		TRANSPONDER #2	
	PASS	FAIL	PASS	FAIL
512 MHz				
36.0000				

NOTES:

TECHNISONIC INDUSTRIES LIMITED

- F. Modulate the TDFM-9200 transmitter on the following frequencies for at least 20 seconds. Observe the DME displays. Look for loss of distance information on the display.

FREQUENCIES		RESULTS	
DME 1	TDFM-9200	PASS	FAIL
978 (108.0)	489		
1020 (112.1)	510		

FREQUENCIES		RESULTS	
DME 2	TDFM-9200	PASS	FAIL
978 (108.0)	489		
1020 (112.1)	510		

NOTES:

TECHNISONIC INDUSTRIES LIMITED

- G. NOTE:** For the following tests, select a frequency at the top, middle, and bottom of each band of the TDFM-9200 transceiver.

136 to 174 MHz Band	403 to 470 MHz Band	450 to 512 MHz Band	806 to 870 MHz Band	Analog Band
------------------------	------------------------	------------------------	------------------------	----------------

Frequency #1

Frequency #2

Frequency #3

- H.** At a safe altitude, engage the autopilot or stability augmentation system. Modulate the TDFM-9200 transmitter on the above frequencies for at least 20 seconds. Observe any effect on the autopilot or stability augmentation system.

Observations:

- I.** Perform a coupled ILS approach to the aircraft's certified limits. Modulate the TDFM-9200 transmitter on the above frequencies for at least 20 seconds. Observe any effect on the autopilot. Repeat for second flight director/autopilot if equipped.

Observations:

TECHNISONIC INDUSTRIES LIMITED

J. List the power plant, fuel, and other electric instruments in the chart provided and note any anomalies that occur while transmitting. Assess the results.

STEP	SYSTEM	PASS	FAIL	NOTES
1	Com 1 & 2 (UHF Lo, UHF Hi, and 800 MHz)			
2	Transponder & Encoder (VHF, UHF Lo, and 800 MHz)			
3	ADF 1 & 2			
4	VG			
5	Glideslope 1 & 2 (UHF Lo, UHF Hi, and 800 MHz)			
6	VOR/LOC 1 & 2 (UHF Lo, UHF Hi, and 800 MHz)			
7	Compass			
8	Directional Gyro			
9	Fuel Pressure			
10	Oil Temp			
11	Amps			
12	Bus Voltage			

TECHNISONIC INDUSTRIES LIMITED

13	Fuel %			
14	Ng			
15	TOT			
16	Torque %			
17	Annunciators			
18	Digital Clock			
19	Oil Pressure			
20	DME 1 & 2 (VHF, UHF Lo, and 800 MHz)			
21	GPS 1 & 2 (UHF Lo and 800 MHz)			

TECHNISONIC INDUSTRIES LIMITED

STEP	SYSTEM	PASS	FAIL	NOTES

NOTES:

APPENDIX A

SUPPORT NOTES

- For the latest Service Bulletin(s) refer to the Publication Index list under the section for this model (*login required*).
- For the latest Technical Information Bulletins refer to the Publication Index list under the section for this model (*login required*).
- For the latest Software Release(s) refer to the Publication Index list under the section for this model's software/firmware history index (*login required*).

TECHNISONIC INDUSTRIES LIMITED

NOTES

ENVIRONMENTAL QUALIFICATION FORM

NOTE: *TDFM-9200 Environmental Qualification results are based on TDFM-9300 testing.*

Model No: TDFM-9300
Part No: 111267-1-93-A10-T5/93037
Description: Airborne Transceiver

Manufacturer: Technisonic Industries Limited
240 Traders Blvd.,
Mississauga, Ontario
Canada
L4Z 1W7

Tel: 905-890-2113
Fax: 905-890-5338

Tested to: RTCA / DO-160G (December 8, 2010)

Date Tested: March 27, 2014 – May 2, 2014

Test Report No: 14RE497

TECHNISONIC INDUSTRIES LIMITED

CONDITIONS	SECTION	CATEGORY	COMMENTS
Temperature and Altitude	4.0	A2, B1, C4, D1	
Low Temperature – Survival	4.5.1		- 55 degrees C
Low Temperature – Short Time Operating	4.5.1		- 40 degrees C
Low Temperature – Operating	4.5.2		- 30 degrees C
High Temperature – Survival	4.5.3		+ 85 degrees C
High Temperature – Short Time Operating	4.5.3		+ 70 degrees C
High Temperature – Operating	4.5.4		+ 70 degrees C
In-Flight Loss of Cooling	4.5.5		not applicable
Altitude	4.6.1		50,000 feet
Decompression	4.6.2		50,000 feet
Overpressure	4.6.3		- 15,000 feet
Temperature Variation	5.0	B	+/- 5 degrees C per minute
Humidity	6.0	X	Not tested
Operational Shock and Crash Safety	7.0	A	Standard Operational Shocks (NOTE-3)
Vibration	8.0	S	Sinusoidal Vibration – curve M
		S	Random Vibration – curve B
		U	Sine-On-Random Vibration – curve G
Explosive Atmosphere	9.0	X	Not tested
Waterproofness	10.0	X	Not tested
Fluids Susceptibility	11.0	X	Not tested
Sand and Dust	12.0	X	Not tested
Fungus	13.0	X	Not tested
Salt Fog Test	14.0	X	Not tested
Magnetic Effect	15.0	Z	Distance result was 0.01 meters
Power Input	16.0	B	NOTES-2, 3
Voltage Spike	17.0	B	NOTE-3
Audio Frequency Susceptibility	18.0	B	NOTE-3
Induced Signal Susceptibility	19.0	X	Not tested
Radio Frequency Susceptibility	20.0	X	Not tested
Radio Frequency Emission	21.0	M	NOTE-1
Lightning Induced Transient Susceptibility	22.0	X	Not tested
Lightning Direct Effects	23.0	X	Not tested
Icing	24.0	X	Not tested

TECHNISONIC INDUSTRIES LIMITED

CONDITIONS	SECTION	CATEGORY	COMMENTS
Electrostatic Discharge	25.0	X	Not tested
Fire, Flammability	26.0	X	Flammability – See NOTE-4
Other Tests			

Remarks:	
	All testing was performed at Technisonic Industries unless otherwise indicated.
NOTE-1	Indicated test was performed by ULTRATECH LABS.
NOTE-2	Testing included subparagraph 16.6.1.3b: Requirement for Equipment with Digital Circuits.
NOTE-3	Approval for this category is based on similarity to the TDFM-9000. See test report 13RE469.
NOTE-4	Only applies to units with “MOD 6” marked on the modifications label.

TECHNISONIC INDUSTRIES LIMITED

Technisonic Industries Limited
240 Traders Blvd., Mississauga, ON Canada L4Z 1W7
Tel: (905) 890-2113 Fax: (905) 890-5338

**IMPORTANT
WARRANTY**

All communication equipment manufactured by Technisonic Industries Limited is warranted to be free of defects in Material or Workmanship under normal use for a period of one year from Date of Purchase by the end user.

Warranty will only apply to equipment installed by a factory approved and/or authorized facility in accordance with Technisonic published installation instructions. Equipment falling under the following is not covered by warranty:

- Equipment that has been repaired or altered in any way as to affect performance,
- Equipment that has been subject to improper installation,
- Equipment that has been used for purposes other than intended,
- Equipment that has been involved in any accident, fire, flood, immersion, or subject to any other abuse.

Expressly excluded from this warranty are changes or charges relating to the removal and re-installation of equipment from the aircraft. Technisonic will repair or replace (at Technisonic's discretion) any defective transceiver (or part thereof) found to be faulty during the Warranty Period.

Faulty equipment must be returned to Technisonic (or its authorized Warranty Depot) with transportation charges prepaid. Repaired (or replacement) equipment will be returned to the customer with collect freight charges. If the failure of a transceiver occurs within the first 30 days of service, Technisonic will return the repaired or replacement equipment prepaid.

Technisonic reserves the right to make changes in design, or additions to, or improvements in its products without obligation to install such additions and improvements in equipment previously manufactured. This Warranty is in lieu of any and all other warranties express or implied, including any warranty of merchantability or fitness, and of all other obligations or liabilities on the part of Technisonic.

This Warranty shall not be transferable or assignable to any other persons, firms, or corporations.

**For warranty registration, please complete the online
Warranty Registration Form found at www.til.ca.**