



# TDAP-650

AUDIO PANEL



## Installation Instructions

TiL Document No. 17RE583  
Rev. N/C

DECEMBER 2018

---

### Technisonic Industries Limited

240 Traders Boulevard, Mississauga, Ontario L4Z 1W7  
Tel: (905) 890-2113 Fax: (905) 890-5338  
[www.til.ca](http://www.til.ca)

---

Copyright by Technisonic Industries Limited. All rights reserved.

This page is intentionally left blank.

TECHNISONIC INDUSTRIES LIMITED

**REVISION HISTORY**  
[ 17RE583 ]

For the most current revision of this document, please check the Technisonic website: [www.til.ca](http://www.til.ca)

REV	SECTION - PAGE -	DESCRIPTION	DATE	EDITED BY
N/C		Original document release.	Dec. 05, 2018	A.L.

This page is intentionally left blank.

## NOTES

### **ESD CAUTION**



This unit contains static sensitive devices. Wear a grounded wrist strap and/or conductive gloves when handling printed circuit boards.

### **WARNING AND DISCLAIMER**

Changes or modifications not expressly approved by Technisonic Industries could void the user's authority to operate the equipment.

This manual is designed to provide information about the TDAP-650. Every effort has been made to make this manual as complete and accurate as possible.

### **WARRANTY INFORMATION**

The Model TDAP-650 Audio Panel is under warranty for one year from date of purchase. Failed units caused by defective parts or workmanship should be returned to:

Technisonic Industries Limited  
240 Traders Boulevard  
Mississauga, Ontario L4Z 1W7

Tel: (905) 890-2113  
Fax: (905) 890-5338

**TECHNISONIC INDUSTRIES LIMITED**

**SUMMARY OF DO-160G ENVIRONMENTAL TESTING**

Summary of DO-160G Environmental Testing for the Technisonic Model TDAP-650 Audio Panel:

<b>CONDITIONS</b>	<b>PARAGRAPH</b>	<b>CATEGORY</b>
Temperature and Altitude	4.0	A2, B2, D1
Temperature Variation	5.0	B
Humidity	6.0	A
Operational Shocks and Crash Safety	7.0	B
Vibration: Sinusoidal Profile M Random Profile B Sine-on-random Profile G	8.0	S, U
Magnetic Effect	15.0	Z
Power Input	16.0	B
Voltage Spike	17.0	B
Audio Frequency Susceptibility	18.0	B
Induced Signal Susceptibility	19.0	ACE
Radio Frequency Susceptibility	20.0	T
Emission of Radio Frequency Energy	21.0	M
Lightning Induced Transient Susceptibility	22.0	A3E3XX
Electrostatic Discharge	25.0	A
Fire, Flammability	26.0	C

**TABLE OF CONTENTS**

SECTION	TITLE	PAGE
<b>1</b>	<b>GENERAL DESCRIPTION</b>	
1.1	INTRODUCTION .....	1
1.2	DESCRIPTION .....	1
1.3	MODEL VARIATION .....	1
1.4	TECHNICAL CHARACTERISTICS .....	2
1.5	SYSTEM LIMITATIONS .....	3
1.5.1	POWER LIMITATIONS .....	3
1.5.2	FREQUENCY RESPONSE LIMITATIONS .....	3
1.5.3	CROSSTALK LIMITATIONS .....	3
1.5.4	TRANSMISSION PRIORITY .....	3
1.5.5	INDUCED SIGNAL SUSCEPTIBILITY, RF SUSCEPTIBILITY, AND RF EMISSION .....	3
<b>2</b>	<b>INSTALLATION INSTRUCTIONS</b>	
2.1	GENERAL .....	5
2.2	EQUIPMENT PACKING LOG .....	5
2.3	INSTALLATION .....	5
2.4	INSTALLATION KIT – CONTENTS .....	5
2.5	WIRING REQUIREMENTS .....	6
2.6	TDAP-650 AUDIO PANEL INSTALLATION .....	6
2.6.1	CABLE CLEARANCE .....	6
2.6.2	SHIELD GROUNDS .....	6
2.7	INSTALLATION – PIN LOCATIONS AND CONNECTIONS .....	8
2.8	HEADPHONE INSTALLATION .....	11
2.9	MICROPHONE INSTALLATION .....	11
2.10	PTT CONNECTIONS .....	11
2.11	MAIN POWER +28 V <sub>DC</sub> .....	11
2.12	BACKLIGHTING POWER +28 V <sub>DC</sub> OR +5 V <sub>DC</sub> .....	11
2.13	STORAGE .....	11
2.14	POST-INSTALLATION ADJUSTMENTS .....	15
	APPENDIX A Support Notes .....	17
	WARRANTY .....	18

## LIST OF FIGURES

FIGURE	TITLE	PAGE
1	Outline Drawing .....	7
2	TDAP-650 Rear Connectors .....	8
3	Wiring Connections for Communication Transceivers .....	12
4	Wiring Connections for Navigation Receivers, Power, and Configurations .....	13
5	Wiring Connections for User Interfaces .....	14
6	Top Cover Post-Installation Adjustment Locations .....	15
7	Bottom Cover Post-Installation Adjustment Locations .....	16

## LIST OF TABLES

TABLE	TITLE	PAGE
1	TDAP-650 General Specifications .....	2
2	Bottom Connector - J101 (50-Pin D Connections) - Use FEMALE Connector .....	8
3	Bottom Connector – J202 (15-Pin D Connections) - Use MALE Connector .....	9
4	Top Connector – J201 (37-Pin D Connections) - Use FEMALE Connector .....	9
5	Top Connector – J102 (15-Pin D Connections) - Use FEMALE Connector .....	10



## SECTION 1: GENERAL DESCRIPTION

### 1.1 INTRODUCTION

This publication provides operating information for the TDAP-650 Audio Panel. The TDAP-650 is only available with Night Vision Goggle (NVG) optimized panel lighting.

### 1.2 DESCRIPTION

The Technisonic Digital Audio Panel (TDAP) Audio Management System TDAP-650 is a panel mounted Digital Audio System that provides centralized control and management for all audio signals within the airframe for up to 7 distinct Users (Pilot, Co-pilot, and five passengers) with varying degrees of connectivity depending on their station.

The TDAP-650 connects to all aircraft Transceivers (up to a maximum of 8 distinct Transceiver Inputs), Navigational Receivers (up to a maximum of 8 distinct Receiver Inputs), Externally Alerting Sirens, and User Headsets. The unit includes functionality allowing expansion to an external PA or Paging system; it also supports full Simulcast transmitting as well as Monitor Only functionality amongst all connected Transceivers.

To reduce pilot workload and avoid operational problems, ACCESS/D™ systems have auto-RX switching when a transmitter is selected. The TDAP-650 has front panel selectable and adjustable VOX, LIVE, or KEYED intercom (ICS) functions.

An EMERGENCY mode locking toggle provides "straight through" or "fail-passive" transmit and receive audio for the pilot or other user on a pre-set radio.

In the NORMAL position (front panel LED is green), the pilot's audio is provided as selected by all of the panel controls and is part of the ICS system. Separate RX and ICS volume controls are provided on the panel along with an ICS VOX threshold control.

### 1.3 MODEL VARIATION

There is no model variation. The TDAP-650 is only available with Night Vision Goggle (NVG) optimized panel lighting

1.4 TECHNICAL CHARACTERISTICS

<b>TDAP-650 GENERAL SPECIFICATIONS</b>	
<b>MODEL TDAP-650 - ACCESS/A Audio Controller:</b>	
<b>PHYSICAL CHARACTERISTICS:</b>	
Width (max.) .....	5.73 inches
Height (max.) .....	2.24 inches
Depth (behind panel) .....	4.59 inches
Weight .....	2.23 lbs. (1.01 Kg)
Mounting .....	Standard Dzus, 4 fasteners
<b>POWER SOURCE REQUIREMENTS:</b>	
DC Voltage (MIN, TYPICAL, MAX).....	15.0 V, 28 V, 32.2 V (System performance will be degraded at upper and lower limits)
DC Current .....	< 1 A
Backlighting Input:	
High Level Backlighting Voltage .....	0-28 V <sub>DC</sub> @ 20 mA Max.
Low Level Backlighting Voltage .....	0-5 V <sub>DC</sub> @ 20 mA Max.
<b>TECHNICAL CHARACTERISTICS:</b>	
Input Impedance (Normal Mode, any RX input) .....	5k1 Ω (approx.)
Headset Channel Output Impedance .....	30 Ω
H/S Audio Power Output.....	At least 250 mW into 150 Ω
Speaker Power Output .....	At least 2.5 W into 8 Ω
Audio Distortion (Speaker or H/S) .....	Less than 2% THD @ 1 kHz at total rated output
Audio Frequency Response (ICS) .....	Within 3 dB from 300 Hz to 6000 Hz
Audio Frequency Response (RX & NAV) .....	Within 3 dB from 300 Hz to 3000 Hz
Hum and Noise Level .....	Better than -60 dB below 500 mW
Input to Input Isolation.....	Better than -70 dB between inputs
Deselected Input Isolation .....	better than -65 dB
Serial Connection.....	Proprietary
<b>ENVIRONMENTAL:</b>	
Temperature (Operating) .....	-45°C to +70° Celsius
Temperature (Survival Non-Operating) .....	-55°C to +85° Celsius
Humidity .....	95% Non-condensing
Shock .....	12 g (any axis)
Altitude .....	15,000 feet

TABLE 1: TDAP-650 General Specifications

# TECHNISONIC INDUSTRIES LIMITED

## 1.5 SYSTEM LIMITATIONS

A summary of the relevant system limitations is given below.

### 1.5.1 POWER LIMITATIONS

With Standard Set-up, which consists of seven headsets connected, a power output of not less than 250 mW is delivered per headset (as represented by 150 ohms).

Nominal microphone input: 250 mV<sub>rms</sub>; Nominal Communications/Navigational Input: 2.5 V<sub>rms</sub>.

### 1.5.2 FREQUENCY RESPONSE LIMITATIONS

In accordance with the provisions made in RTCA/DO-214 Sections 2.8.1 and 1.5.1, the communications transmit out and receiver channels (communications and navigational) possess an effective bandwidth of 300 Hz – 3000 Hz with a maximum amplitude variation of 3 dB within the frequency range.

### 1.5.3 CROSSTALK LIMITATIONS

To ensure that the crosstalk specifications are in accordance with the applicable sections of DO-214, it is essential that:

- 1) Manufacturer's maximum microphone input voltage of -4.7 dBu must not be exceeded in order to avoid jeopardising input to microphone output crosstalk results, particularly at the low frequency end.
- 2) In the instance where only two access units are daisy chained via their ICS tie-lines, a resistor of not greater than 600 ohms must be maintained across the ICS tie-line in order to avoid jeopardising station to station crosstalk results in RX mode at the high frequency end.

When multiple transceivers are selected for simulcast operation, they are bound together at the station output; thus, they are also bound together for other stations as well and defeat crosstalk measurements. All measurements are based on single transceiver TX selection.

### 1.5.4 TRANSMISSION PRIORITY

Where Pilot and Co-pilot transmit simultaneously, the Pilot transmissions take precedence over those of the Co-pilot. Co-pilot transmissions in this case would be rendered inactive.

### 1.5.5 INDUCED SIGNAL SUSCEPTIBILITY, RF SUSCEPTIBILITY, AND RF EMISSION

The wiring connections called out in Section 2 describe shield terminations for minimum ground loop noise. The test harnesses used for RTCA/DO-160 Sections 19, 20, and 21 – Induced Signal Susceptibility, RF Susceptibility, and Emission of RF Energy respectively – used shield terminations at both ends of the cable. Should RF susceptibility pose a problem in a particular installation, the installer may wish to try terminating shields at both ends of the cable. If this does not produce satisfactory results, then double shielding may be required.

This page is intentionally left blank.

## SECTION 2: INSTALLATION INSTRUCTIONS

### 2.1 GENERAL

This section contains information and instructions for the correct installation of the TDAP-650 Audio Panel.

Make certain that the unit is correctly operating in accordance with the equipment user's requirements and manufacturer's specifications, prior to releasing the equipment for service.

### 2.2 EQUIPMENT PACKING LOG

Unpack the equipment and check for any damage that may have occurred during transit. Save the original shipping container for returns due to damage or warranty claims. Check that each item on the packing slip has been shipped in the container.

### 2.3 INSTALLATION

The TDAP-650 Audio Panel is designed to be Dzus mounted and should be installed in conjunction with an IN-TDAP650 installation kit. See Figure 1 for an outline drawing of the unit with dimensions to facilitate the installation.

- For aircraft approved for Single Pilot IFR operations, the VHF Radio that is connected to the emergency bus (and must remain available during emergency procedures) must be interfaced to the No. 1 Transceiver Input channel of the audio panel.
- For aircraft where the minimum crew is more than one pilot, an audio panel must be installed at each required pilot station. The respective pilot's inside VHF Radio must be connected to the No. 1 Transceiver Input channel of his/her audio panel.
- All external aural warning systems that are required to remain available to the flight crew during emergency conditions or after a normal functional failure of the audio panel must be connected to the "Direct Alert Input" channel of the audio panel.

### 2.4 INSTALLATION KIT – CONTENTS

The IN-TDAP650 installation kit (P/N 179704) consists of:

1. One 50-Pin Cannon D mating connector (female) complete with crimp pins and hood.
2. One 37-Pin Cannon D mating connector (female) complete with crimp pins and hood.
3. One 15-Pin Cannon D mating connector (female) complete with crimp pins and hood.
4. One 15-Pin Cannon D mating connector (male) complete with crimp pins and hood.

## 2.5 WIRING REQUIREMENTS

Airframe wiring should be either:

- 1) Single conductor in accordance with MIL-W-22759 or multi-conductor in accordance with MIL-C-27500.
- 2) Raychem 44 (81044) or 55 single or multi-conductor and shielded wire.

Heat shrink solder sleeves (such as Raychem or equivalent) should be utilized for shield termination.

All microphone audio input and output line connections should be made with 2 conductor, twisted pair shielded cables as illustrated in Figures 3 to 5. Receiver audio input lines should also be 2 conductor, twisted pair shielded cables. The power and ground lines should be a minimum of #22 AWG (#20 preferred). Keying and all audio lines may be #24 AWG or larger.

**NOTE:** Do not bundle any low level audio lines with RF coaxial cables, 60 Hz or 400 Hz AC inverter, or motor, pump, or blower wiring, which can cause noise coupling between the various systems (especially during RF transmission or pump/blower mechanical operation). Maintain as much distance as possible from these types of wire bundles.

Note that there is really no effective field-installable shielding for magnetic coupling (which occurs at high currents), and the only suitable prevention for this type of interference is distance between the interfering lines. Shielded wiring is effective only for electrostatic coupling or voltage driven interference.

## 2.6 TDAP-650 AUDIO PANEL INSTALLATION

### 2.6.1 CABLE CLEARANCE

Allow at least 2.5" of additional rear clearance for mating connectors and hoods (side routing) or 3.0" (back routing). Cables should be long enough to permit the unit to be removed from the panel and the connectors to be easily disengaged. DO NOT dress or strap the mating cables so that front removal is impossible or the unit cannot be removed for service or adjustment in the field.

### 2.6.2 SHIELD GROUNDS

Convenient shield ground connections are provided at each connector for the indicated input signal shield drains and will give the shortest possible return for these lines. These shield lines should be daisy chained together and a single wire from each cable brought out to the designated connector pin.

TECHNISONIC INDUSTRIES LIMITED

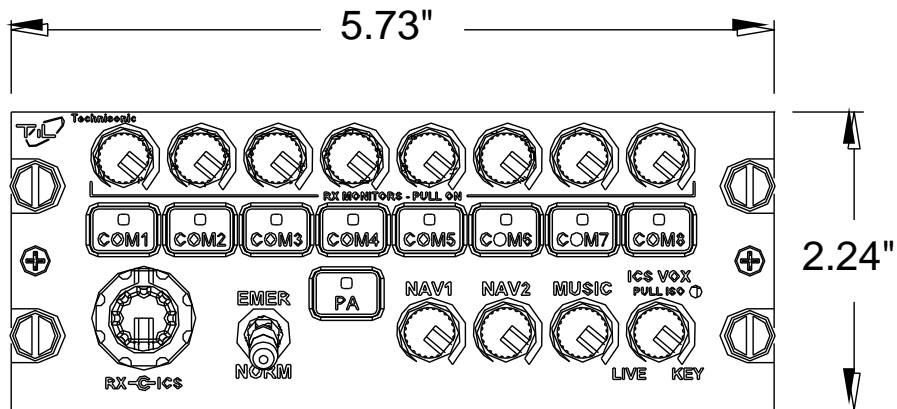
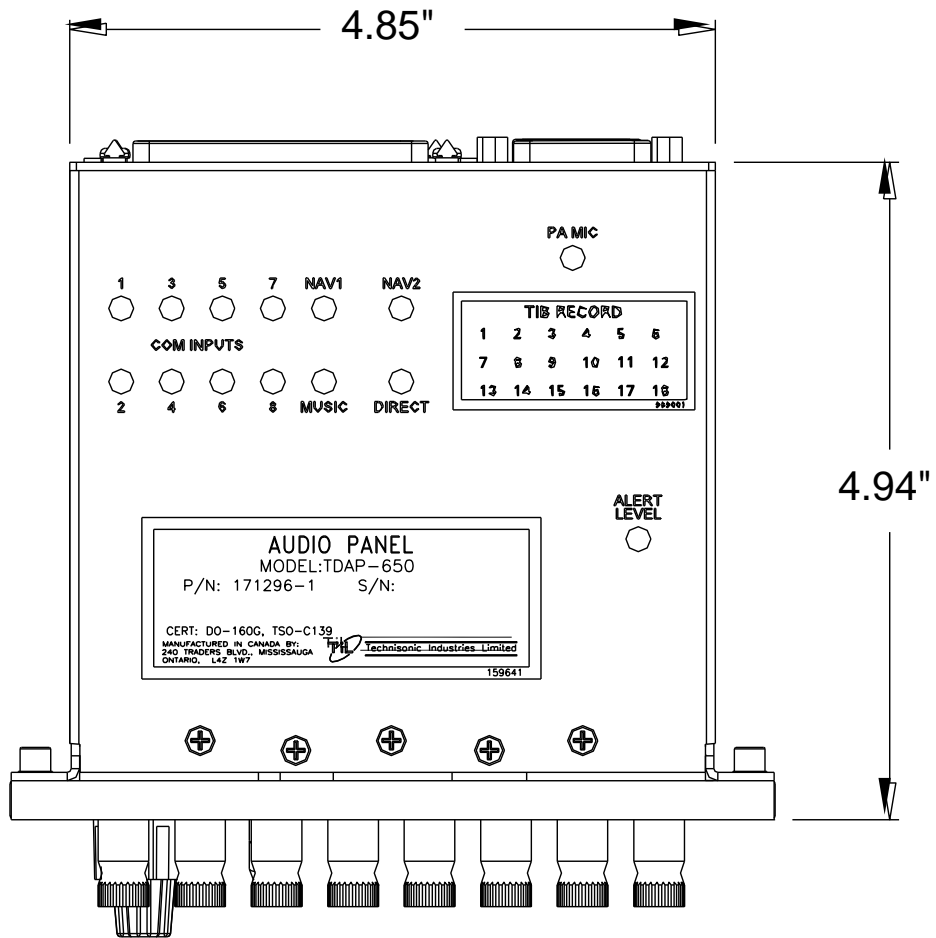

FIGURE 1: Outline Drawing for Model TDAP-650

2.7 INSTALLATION – PIN LOCATIONS AND CONNECTIONS

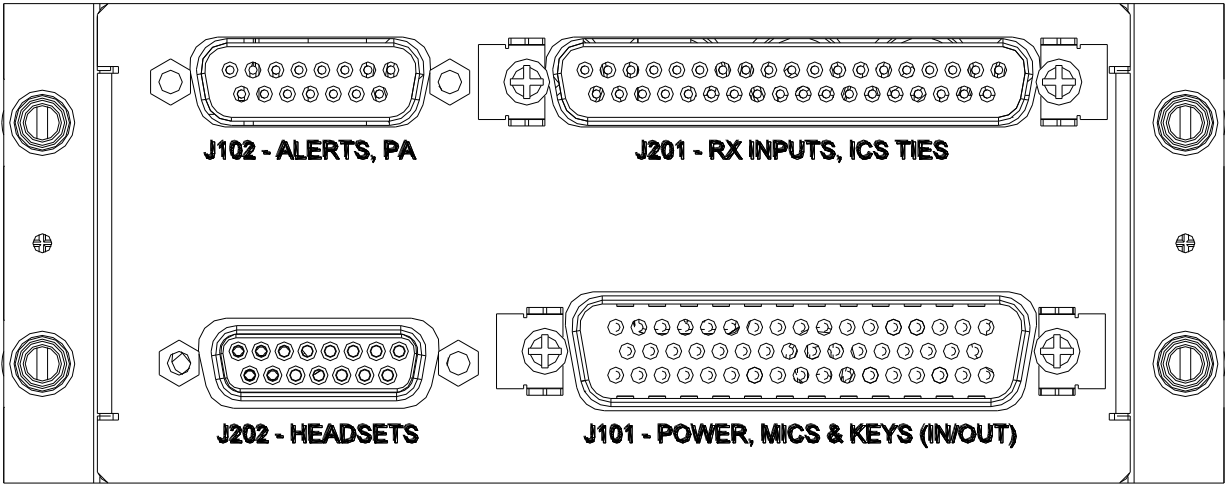

FIGURE 2: TDAP-650 Rear Connectors

J101 – POWER, MICS & KEYS Connector Pin Assignments				
LO	HI	KEY	Connection	Notes
34	17		+28 V <sub>DC</sub> Power In	Main Power Input
40	23	6	Pilot's Mic In	
		9	Pilot's ICS Key	Active when grounded
41	24	7	Co-Pilot's Mic In	
		26	Co-Pilot's ICS Key	Active when grounded
42	25	8	Hand Mic In	Emergency Hand Mic
35	18		PAX 1 Mic In	
36	19		PAX 2 Mic In	
37	20		PAX 3 Mic In	
38	21		PAX 4 Mic In	
39	22		PAX 5 Mic In	
		4	PAX ICS Key	
1	3		Backlighting Power Input	
		2	Lighting 28 V / 5 V Select	Open: 28 V Backlighting Ground: 5 V Backlighting
		5	Speaker Volume Control	10K Pot: Speaker Volume Ground: Speaker Disabled
44	27	10	COM 7 TX Mic Out	
45	28	11	COM 6 TX Mic Out	
46	29	12	COM 5 TX Mic Out	
47	30	13	COM 4 TX Mic Out	
48	31	14	COM 3 TX Mic Out	
49	32	15	COM 2 TX Mic Out	
50	33	16	COM 1 TX Mic Out	
43				Shield ground for mic lines

TABLE 2: Bottom Connector - J101 (50-Pin D Connections) - Use FEMALE Connector



**TECHNISONIC INDUSTRIES LIMITED**

<b>J202 – HEADSETS CONNECTOR PIN ASSIGNMENTS</b>			
<b>LO</b>	<b>HI</b>	<b>Connection</b>	<b>Notes</b>
9	1	Pilot's H/S Audio	
10	2	Direct Alert Connection	High level headset direct audio (via resistive pad). Never connect together between multiple units.
11	3	Co-Pilot's H/S Audio	
	4	PAX 1 H/S Audio	
	5	PAX 2 H/S Audio	
	12	PAX 3 H/S Audio	
	13	PAX 4 H/S Audio	
	6	PAX 5 H/S Audio	
14		PAX H/S Common	
15	7	Speaker Output	8 Ohms
	8	Shield Ground	

**TABLE 3:** Bottom Connector – J202 (15-Pin D Connections) - Use MALE Connector

The Pin 2/10 Direct Input is connected directly to the pilot's H/S via a resistive pad and, if multiple units use this connection to a common source, significant crosstalk will result. Connect ONLY ONE station in this way to a single external source.

<b>J201 – RX INPUTS, ICS TIES CONNECTOR PIN ASSIGNMENTS</b>			
<b>LO</b>	<b>HI</b>	<b>Connection</b>	<b>Notes</b>
20	1	CREW ICS Tie	ICS Tie Line Between Units
21	2	PAX ICS Tie	ICS Tie Line Between Units
22	3	Direct Audio 1	Un-switched Direct Input
4		Shield Ground	Shield drain for input lines.
23	24	Digital Audio Connection	Proprietary Connection to Technisonic Radios
	5	NAV 8 RX Audio	Mapped to NAV2 knob
	6	NAV 7 RX Audio	Mapped to NAV2 knob
25	7	Music Left Audio	Mapped to MUSIC knob
26	8	Music Right Audio	Mapped to MUSIC knob
27	9	NAV 4 RX Audio	Mapped to NAV1 knob
28	10	NAV 3 RX Audio	Mapped to NAV1 knob
29	11	NAV 2 RX Audio	Mapped to NAV1 knob
30	12	NAV 1 RX Audio	Mapped to NAV1 knob
31	13	COM 7 RX Audio	
32	14	COM 6 RX Audio	
33	15	COM 5 RX Audio	
34	16	COM 4 RX Audio	
35	17	COM 3 RX Audio	
36	18	COM 2 RX Audio	
37	19	COM 1 RX Audio	

**TABLE 4:** Top Connector – J201 (37-Pin D Connections) - Use FEMALE Connector

**TECHNISONIC INDUSTRIES LIMITED**

<b>J102 – ALERTS, PA CONNECTOR PIN ASSIGNMENTS</b>			
<b>LO</b>	<b>HI</b>	<b>Connection</b>	<b>Notes</b>
9	1	Direct Audio 2	Un-switched Direct Input
11	3	PA Mic Out	To External PA System
	2	PA Key Output (Active Low)	To External PA system
	10	PA Power Key Output (Active Low)	To External PA system Can be used to activate a remote PA system.
12	4	COM 8 RX Audio	
6	5	COM 8 TX Mic Out	
	7	COM 8 TX Key	
	8	PAX RX Enable	Open: PAX receive no RX Audio Ground: PAX receive RX Audio
	13	Alert 3 (in) Two-Tone, Timed (Rad Alt DH)	Active when grounded. Accepts +28 V <sub>DC</sub> .
	14	Alert 2 (in) Pulsing Tone (Low Rotor)	Active when grounded. Accepts +28 V <sub>DC</sub> .
	15	Alert 1 (in) Steady Tone (Engine Fail)	Active when grounded. Accepts +28 V <sub>DC</sub> .

**TABLE 5:** Top Connector – J102 (15-Pin D Connections) - Use FEMALE Connector

Alerting is tone based with Alert 1 emitting a steady tone, Alert 2 a pulsing tone, and Alert 3 a two-tone, timed signal.

Alert 2 has priority over Alert 1 if both are activated at the same time. Alert 3 has priority over Alert 2 and Alert 1.

## 2.8 HEADPHONE INSTALLATION

The TDAP-650 Audio Panel is intended for use with industry standard 150 ohm headphones. In all cases, the headset lines should be run as shielded, twisted pairs, to avoid contamination (and resulting crosstalk) of companion low level mic lines or audio input lines. Failure to follow this wiring guideline will result in unwanted crosstalk and phantom audio that will appear to be transmit or intercom related.

The use of high quality headsets and “carbon-equivalent” boom microphones, such as David Clark or Bose, is strongly recommended. The use of headsets with individual volume controls is very useful for passengers and allows level adjustment suitable to each position due to differing headsets and the inevitable different hearing capability of individual users.

## 2.9 MICROPHONE INSTALLATION

All microphone connections to the TDAP-650 must be done with shielded cables. The inputs are intended for use with standard “carbon-equivalent” or amplified dynamic microphones (such as the D/C M1, M4 M7, etc.). Shielded, twisted pair routing is strongly preferred for lowest noise pick-up, but single conductor shielded wiring generally gives adequate results in non-critical or single box installations (although noise floor and crosstalk will increase).

## 2.10 PTT CONNECTIONS

The Pilot, Co-pilot, and hand microphones require a PTT (Push To Talk) button or switch to key the transceivers as required. If a hand-held microphone is used, tie the PTT button to the appropriate key line. If a boom microphone is incorporated into the headset, an external switch (such as the cyclic switch or yoke switch) will be required to key the transmitter. PTT lines should go directly to ground to activate the desired key function.

## 2.11 MAIN POWER +28 V<sub>DC</sub>

The main power +28 V<sub>DC</sub> is connected to Pin 17 of the 50-pin (lower) "D" connector. The main power ground is connected to Pin 34 of the 50-pin (lower) "D" connector.

As previously indicated, this connection should be made with at least #22 AWG wire, with #20 preferred. If from a very noisy source, with high levels of parasitic AC, shielding may improve rejection of this coupled AC into other low level audio lines.

## 2.12 BACKLIGHTING POWER +28 V<sub>DC</sub> or +5 V<sub>DC</sub>

The backlighting power is connected to Pin 3 of the 50-pin (lower) "D" connector. The backlighting ground is connected to Pin 1 of the 50-pin (lower) "D" connector.

The backlighting input voltage level can be switched between a 0-28 V<sub>DC</sub> range of a 0-5 V<sub>DC</sub> through Pin 2 of the 50-pin (lower) "D" connector (Ground = 5 V<sub>DC</sub> Backlighting).

Backlighting is NVG/ANVIS compatible (green).

## 2.13 STORAGE

When not in use, store the TDAP-650 in the original anti-static bag if possible and in a non-humid place. Optimum storage temperatures for the best shelf life should not exceed +35°C or be less than -10°C.

TECHNISONIC INDUSTRIES LIMITED

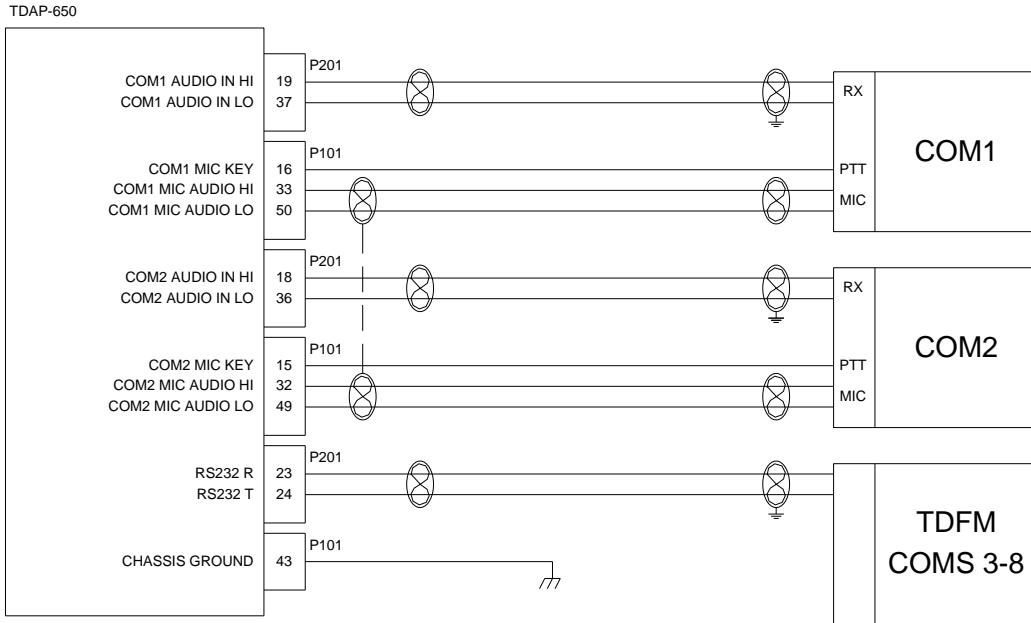

**FIGURE 3:** Wiring Connections for Communication Transceivers

TECHNISONIC INDUSTRIES LIMITED

TDAP-650

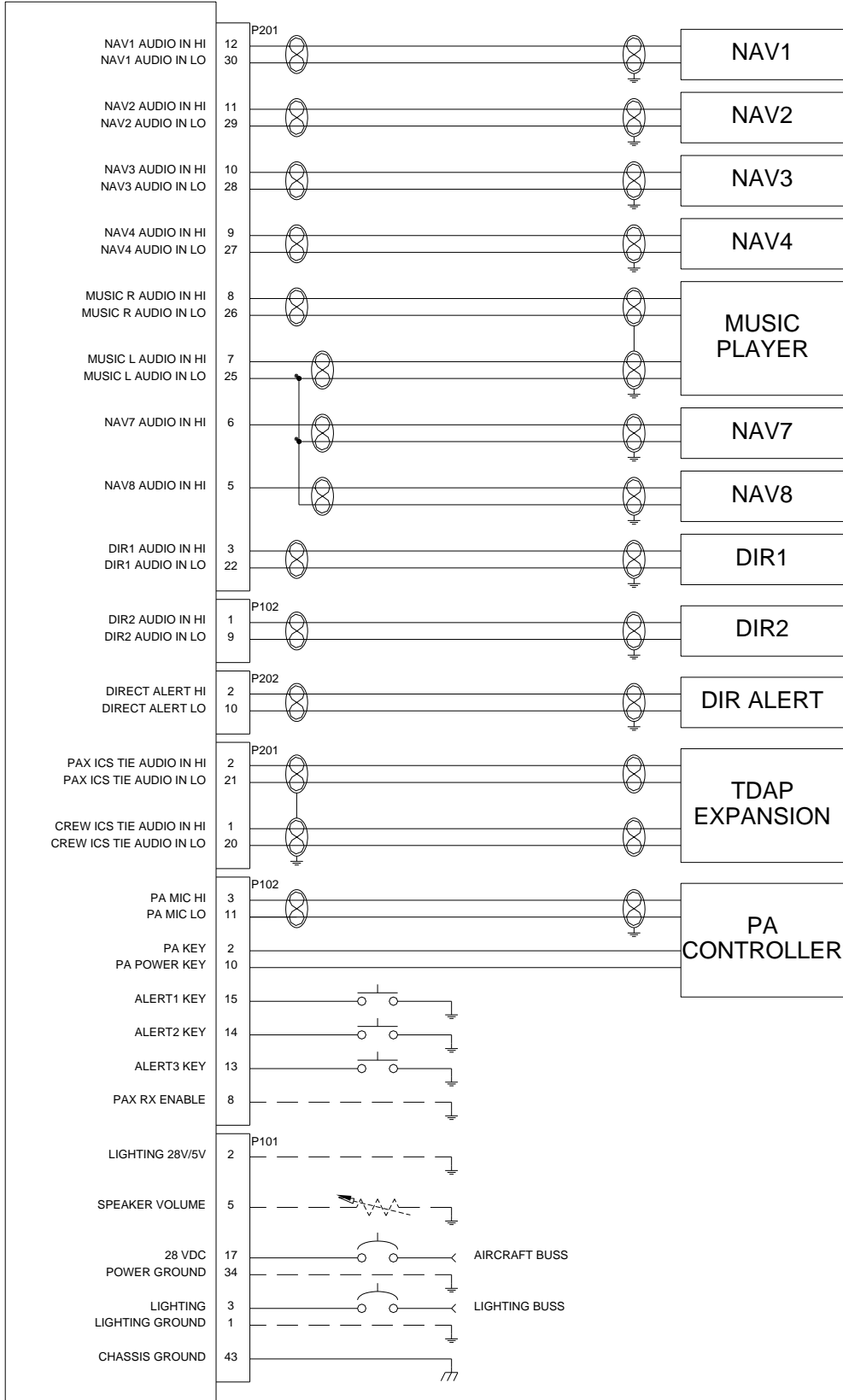

FIGURE 4: Wiring Connections for Navigation Receivers, Power, and Configurations

TECHNISONIC INDUSTRIES LIMITED

TDAP-650

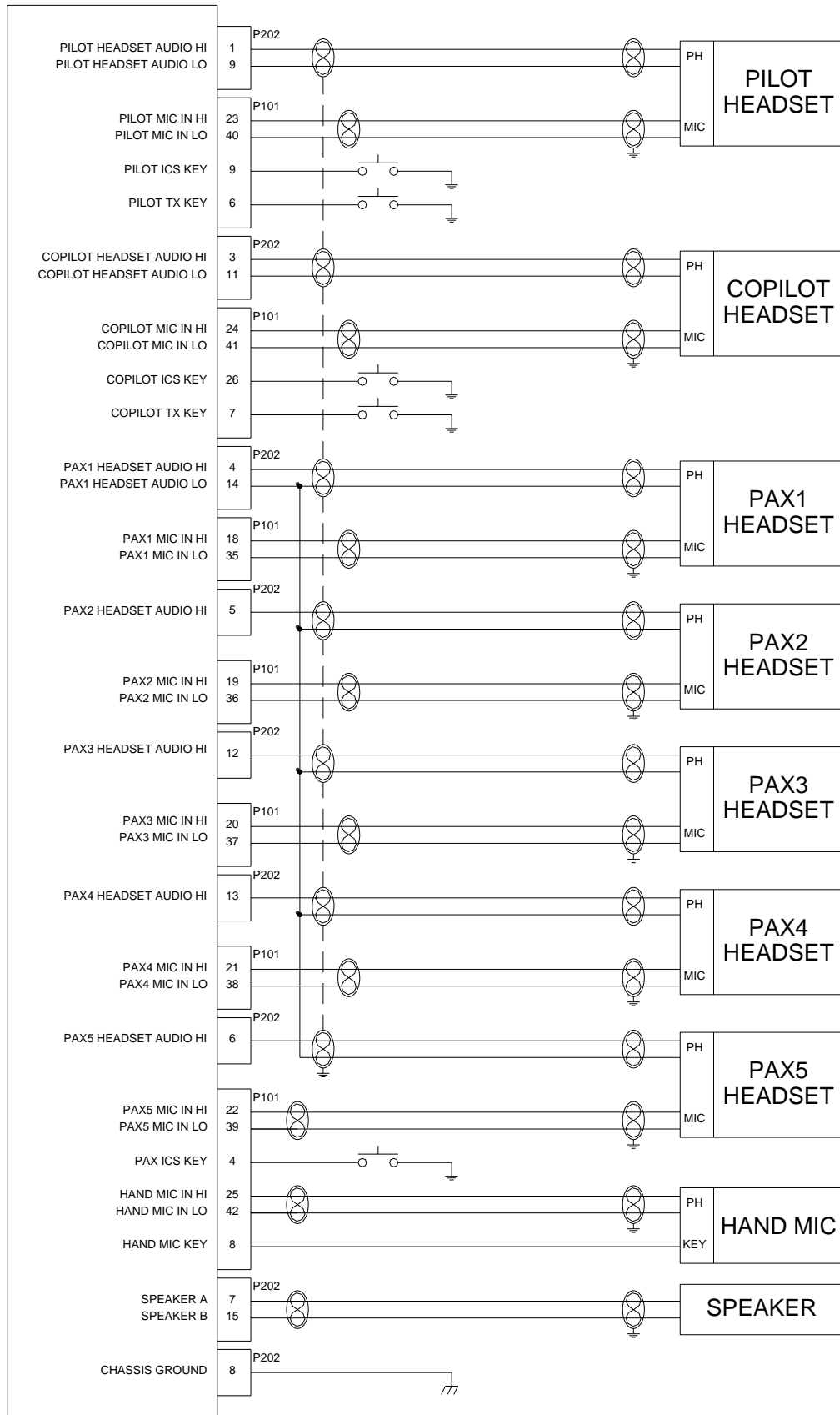
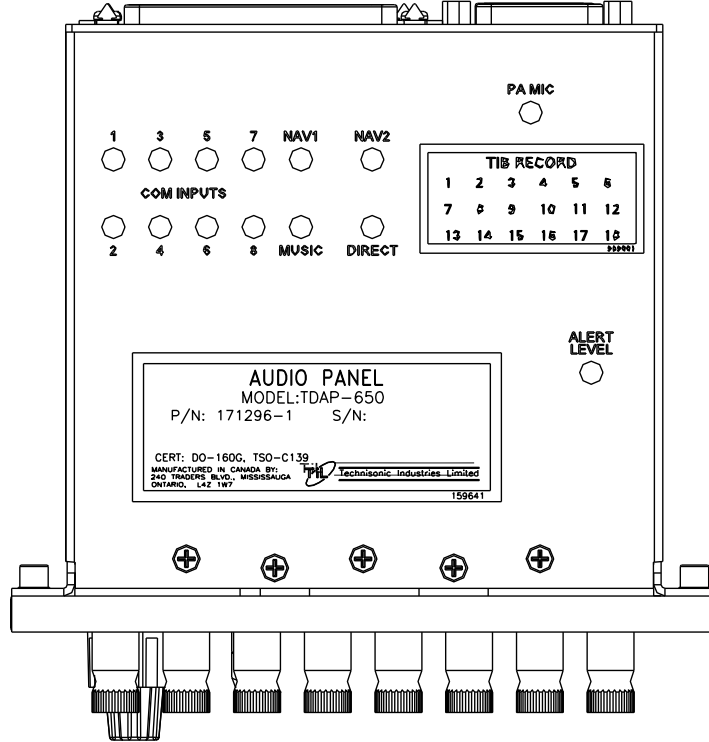

FIGURE 5: Wiring Connections for User Interfaces

**2.14 POST-INSTALLATION ADJUSTMENTS**

After installation, the TDAP-650 may require adjustment of some functions to compensate for airframe and equipment specific issues and to suit user tastes. Locations of these adjustments are as shown. "MUSIC" input may be for any entertainment audio feed, such as CD, tuner, etc.



**FIGURE 6:** Top Cover Post-Installation Adjustment Locations

Adjustment Name	Location	Procedure/Purpose	Notes
<b>COM INPUTS 1 - 8</b>	Top	Adjusts COM Transceiver received audio inputs	Preset. Set to desired level, if required. Only applies to ANALOG inputs
<b>NAV1</b>	Top	Adjusts NAV received audio inputs for NAV1 through NAV4	Preset. Set to desired level, if required. NAV1 through NAV4 are ganged on one control.
<b>NAV2</b>	Top	Adjusts NAV received audio inputs for NAV7 and NAV8	Preset. Set to desired level, if required. NAV7 through NAV8 are ganged on one control.
<b>MUSIC</b>	Top	Adjusts the MUSIC received audio input for MUSIC LEFT and RIGHT	Preset. Set to desired level, if required.
<b>PA MIC</b>	Top	Adjusts the PA Microphone audio output level	Preset. Set to desired level, if required.
<b>ALERT LEVEL</b>	Top	Adjusts the TONE ALERT audio output level	Preset. Set to desired level, if required.

TECHNISONIC INDUSTRIES LIMITED

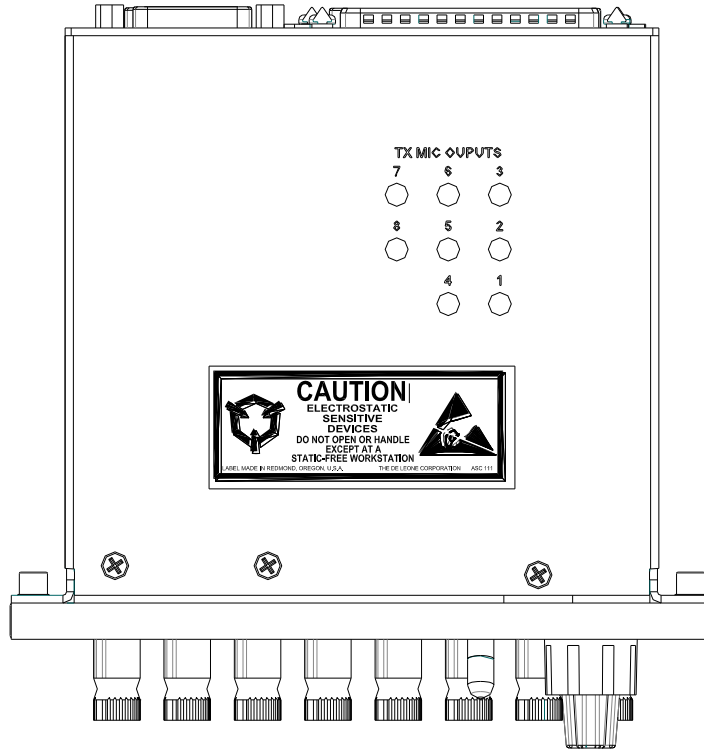

FIGURE 7: Bottom Cover Post-Installation Adjustment Locations

Adjustment Name	Location	Procedure/Purpose	Notes
<b>TX MIC OUTPUTS 1 - 8</b>	Top	Adjusts COM Transceiver Microphone audio output level	Preset. Set to desired level, if required.



## APPENDIX A

### SUPPORT NOTES

- For the latest Service Bulletin(s), please refer to the Publication Index list under the section for this model (*login required*).
- For the latest Technical Information Bulletins, please refer to the Publication Index list under the section for this model (*login required*).
- For the latest Software Release(s), please refer to the Publication Index list under the section for this model's software/firmware history index (*login required*).

### NOTES

**TECHNISONIC INDUSTRIES LIMITED**

**Technisonic Industries Limited**

240 Traders Blvd., Mississauga, ON Canada L4Z 1W7  
Tel: (905) 890-2113 Fax: (905) 890-5338

**IMPORTANT  
WARRANTY**

All communication equipment manufactured by Technisonic Industries Limited is warranted to be free of defects in Material or Workmanship under normal use for a period of one year from Date of Purchase by the end user.

Warranty will only apply to equipment installed by a factory approved and/or authorized facility in accordance with Technisonic published installation instructions. Equipment falling under the following is not covered by warranty:

- Equipment that has been repaired or altered in any way as to affect performance
- Equipment that has been subject to improper installation
- Equipment that has been used for purposes other than intended
- Equipment that has been involved in any accident, fire, flood, immersion, or subject to any other abuse.

Expressly excluded from this warranty are changes or charges relating to the removal and re-installation of equipment from the aircraft. Technisonic will repair or replace (at Technisonic's discretion) any defective transceiver (or part thereof) found to be faulty during the Warranty Period.

Faulty equipment must be returned to Technisonic (or its authorized Warranty Depot) with transportation charges prepaid. Repaired (or replacement) equipment will be returned to the customer with collect freight charges. If the failure of a transceiver occurs within the first 30 days of service, Technisonic will return the repaired or replacement equipment prepaid.

Technisonic reserves the right to make changes in design, or additions to, or improvements in its products without obligation to install such additions and improvements in equipment previously manufactured. This Warranty is in lieu of any and all other warranties express or implied, including any warranty of merchantability or fitness, and of all other obligations or liabilities on the part of Technisonic.

This Warranty shall not be transferable or assignable to any other persons, firms, or corporations.

**For warranty registration, please complete the online  
Warranty Registration Form found at [www.til.ca](http://www.til.ca).**